

Screwdriving technology

Automation

Air motors

Air tools

## Pneumatic Metal Shears

- high cutting speed
- optimum curve adaptability
- lateral material discharge due to the ideal deflector geometry
- high machine uptime

Metal shears are used in the entire sheet-metal industry, for the processing of metals in the automotive-, container-, and shipbuilding industry, as well as in body shops. The shears can be used for either straight- or curved incisions. These tools are especially well-suited for the cutting of metal sheets and coils.

### High cutting speed

The high power of the air-motor and the efficient construction of the cutting knives, allows a maximum cutting capacity into steel of 1,6 mm and into aluminum of 2,5 mm. Additionally, this shears allows smooth operation due to the low feed force. The high amount of impacts assures the finest cutting quality.

### Optimum straight- and curve workability

Our Shears are especially well-suited for a straight- and curved cutting job of sheet-metal or non-ferrous plates. It is possible to adjust the pestle-knives and also to smoothly adjust the knife-positioning during cutting.

### Highly durable

The robust construction assures a high longevity of your tool - even when used in 24/7 operations.

### Ergonomic

Our shears allow a full view of the work-surface and the incision for maximum operational safety.

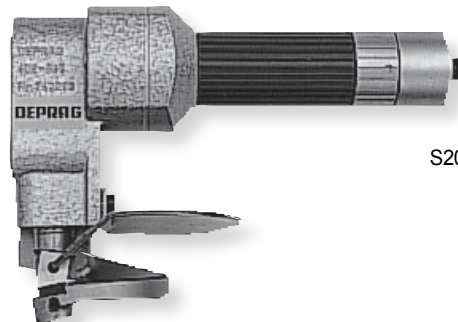

S20-180Y

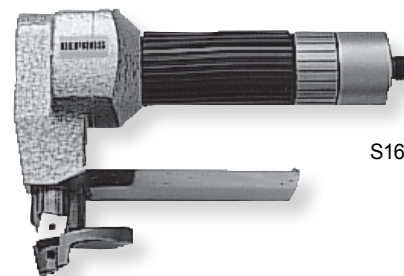

S16-320Y



## SPECIFICATIONS - METAL SHEARS

### Design

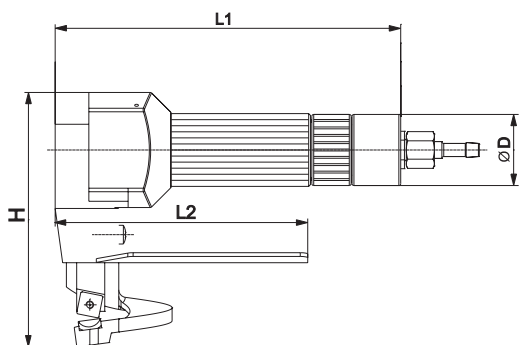

S16-320Y

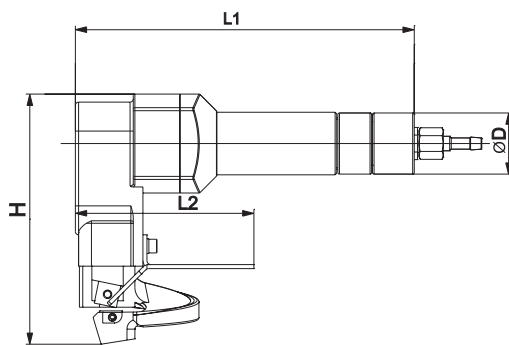

S20-180Y

Metal Shears, handheld	Typ	S16-320Y	S20-180Y
Twist Valve	Part No.	3240971C	3388471A
Max. metal thickness			
Sheet metal up to 400 N/mm <sup>2</sup>	mm (in)	1,6 (.06)	2 (.08)
Sheet metal up to 600 N/mm <sup>2</sup>	mm (in)	1,2 (.05)	1,6 (.06)
Sheet metal up to 800 N/mm <sup>2</sup>	mm (in)	1 (.04)	1,4 (.06)
Aluminum up to 250 N/mm <sup>2</sup>	mm (in)	2 (.08)	2,5 (.10)
Max. power output	W (hp)	320 (.43)	320 (.43)
Air consumption (max. power)	m <sup>3</sup> /min (cfm)	0,4 (14.12)	0,4 (14.12)
Impacts (at full load)	min <sup>-1</sup> (rpm)	3 200	1 800
Cutting speed up to	m/min	7	7
Smallest cutting radius	mm (in)	15 (.59)	20 (.79)
Length L1	mm (in)	185 (7.28)	211 (8.31)
Length L2	mm (in)	135 (5.31)	111 (4.37)
Height H	mm (in)	136 (5.35)	156 (6.14)
Diameter D	mm (in)	38 (1.50)	38 (1.50)
Weight	kg (lbs)	1,6 (.06)	1,9 (4.19)
I.D. of air inlet hose	mm (in)	6 (.24)	6 (.24)
Air connection		thread 1/4"male	thread 1/4"male

Specifications at 90 psi (6,3 barú)

Standard Equipment:	Part Number	
Hose Nozzle	410532	410532
Screw cap	410533	410533
Allen key 2 mm	800443	-
Allen key 2,5 mm	-	800445
Allen key 3 mm	800446	-
Allen key 4 mm	-	800447

# DEPRAG

DEPRAG CZ a.s., Lázně Bělohrad

DEPRAG CZ a.s., T. G. Masaryka 113, 507 81 Lázně Bělohrad - Czech Republic  
 Tel.: +420-493 771 511, Fax: +420-493 771 623, E-mail: sales@deprag.cz, Internet: www.deprag.cz

