

## Cordless Impact Wrenches with automatic shut-off

The solution to interfering cables and hoses  
pistol grip design - torque up to 250 Nm / 2212.5 in.lbs

- maximum flexibility
- powerful
- economic and reliable
- operator friendly

The high powered cordless impact wrench for industrial use enables fast screw assemblies with the very slightest reaction torque. The tightening and loosening of screw connections in the range from M12 to M18 can thereby be exacted with the highest efficiency and optimal ergonomics. Brushless drive technology in combination with top quality Li-Ion batteries guarantees outstanding energy efficiency and first-class screwdriving performance.

Application areas include, amongst others, assembly and maintenance services, the automobile industry, construction industry and mechanical engineering.



## ADVANTAGES



### Powerful

The wrench is equipped with a brushless drive motor. This motor is distinguished by its first-class screwdriving performance and low loss of energy enabling high torques and simultaneously high drive speeds. The cordless impact wrench is suitable for torques up to 250 Nm.

### Maximum Flexibility

Many assembly tasks are hindered by electrical cables or pneumatic hoses. This cordless wrench is most suitable for these assembly tasks.

### Economic and Reliable

Robust drive technology guarantees highest wear resistance and long-term reliability.

### Operator friendly

Low tool weight and ergonomic design provide for low fatigue operation.

## TECHNICAL DATA Cordless Impact Wrenches, handheld, pistol grip design

	Type	300APTS-250
Screwdriver reversible	Part No.	385880A
Trigger/button start		
Operating voltage (DC)	V	18
Speed, idling	rpm	2300
Impacts per minute	rpm	3200
Torque max.	Nm / in.lbs	250 / 2212.5
Dimensions without battery (D x L x H)	mm / in.	90 x 190 x 203 / 3.51 x 7.41 x 7.92
Dimensions with battery (D x L x H)	mm / in.	90 x 190 x 253 / 3.51 x 7.41 x 9.87
Weight (without battery)	kg / lbs	1.1 / 2.42
Square drive DIN 3121	mm / in.	12.5 (1/2")

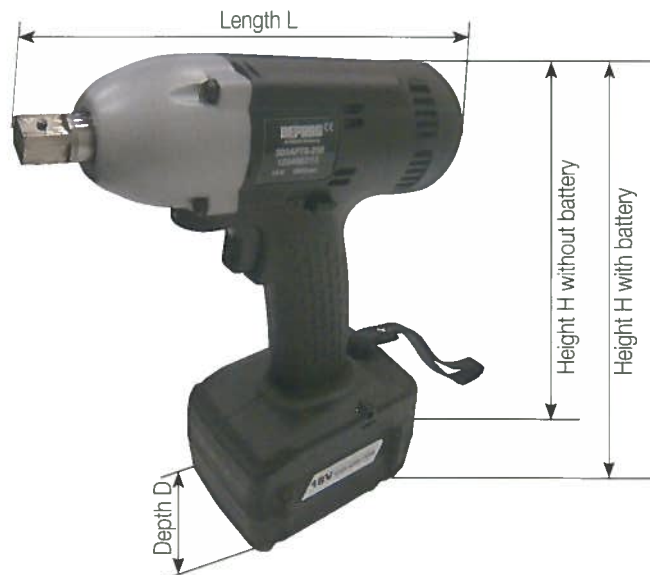

## REQUIRED ACCESSORIES

### Battery

<b>Battery</b>	<b>Type</b> Part no.	<b>Li-Ion 18V 70Wh</b> 815377	<ul style="list-style-type: none"> <li>- Integrated electronics for communication with the nutrunner controller and optimized charge management</li> <li>- High current cells with high power density</li> <li>- Protection functions such as deep discharge, short circuit and overload</li> <li>- Optimized charging of individual battery cells</li> </ul>	
Energy storage	Wh	70		
Weight	kg / lbs	0.7 / 1.54		
Dimensions (W x D x H)	mm in.	119 x 90 x 59 4.64 x 3.51 x 2.3		

### Charger

<b>Charger</b>	<b>Type</b> Part no.	<b>Li-Ion 18V</b> 815379	<ul style="list-style-type: none"> <li>- charging status shown via LED's and signal</li> <li>- battery recognition</li> <li>- intelligent quick charge device (80 % in 30 minutes)</li> <li>- warning signals</li> </ul>	
Operating voltage (AC)	V	90 - 240		
Weight	kg / lbs	0.55 / 1.21		
Dimensions (W x D x H)	mm in.	115 x 147 x 84 4.49 x 5.73 x 3.28		

### Power cable for charger

Power cable EU (2m / 6.56 ft.)	<b>Type</b> Part no.	<b>KN-NG40-EU</b> 833790	
Power cable US (2m / 6.56 ft.)	<b>Type</b> Part no.	<b>KN-NG40-US</b> 833791	
Power cable UK (2m / 6.56 ft.)	<b>Type</b> Part no.	<b>KN-NG40-UK</b> 833792	

# DEPRAG

**DEPRAG INC.**

P.O. Box 1554 · Lewisville, Texas 75067 - 1544  
640 Hembry Street · Lewisville, Texas 75057 - 4777  
Phone (972) 221 - 8731 · FAX (972) 221 - 8163  
TOLL FREE (800) 4 DEPRAG  
[www.deprag.com](http://www.deprag.com)  
[deprag@depragusa.com](mailto:deprag@depragusa.com)



CERTIFIED AS PER DIN EN ISO 9001

---