

DEPRAG

Operating instructions

Pneumatic screwdriver

376-3223
376-0223

337668 C
356663 A

DEPRAG

DEPRAG SCHULZ GMBH u. CO.

Postfach 1352, D-92203 Amberg
Kurfürstenring 12-18, D-92224 Amberg
Telefon (09621) 371-0
Fax (09621) 371-120
Internet: <http://www.deprag.com>
e-mail: info@deprag.de

DEPRAG INC.

P.O. Box 1554 • Lewisville, Texas 75067 – 1554
645 Hembry Street • Lewisville, Texas 75057 – 4726
Phone (972) 221 – 8731 • FAX (972) 221 – 8163
TOLL FREE (800) 4 DEPRAG
Internet: <http://www.deprag.com>
e-mail: deprag@depragusa.com



CERTIFIED AS PER DIN EN ISO 9001

Dec-03 Technical alterations reserved

MINIMAT-ULTRA

Dear Customer:

Congratulations, you chose the enclosed tool from an extensive DEPRAG product line. This tool is the result of more than 60 years experience in the design and manufacturing of pneumatic tools for the industrial market. We offer a complete program of pneumatic tools, such as Drills, Tappers, Grinders, Screwdrivers, Impact Wrenches, Metal Working Tools and Hammers.

Please call us for all of your needs, from individual hand tools to the complete automated screwdriving cell. Our products offer solutions to any and all requirements, which are needed in the screwdriving sector.

We kindly ask, that you read these operating instructions carefully, so that you will be able to use this tool safely and for many years to come. If you need additional information, please contact your DEPRAG Representative or contact us direct at DEPRAG. We will be happy to answer any questions.

We hope you will be pleased with your new tool!

Content:	Page:
1. Operating Instruction	2
1.1 Safety Tips	2
1.2 Application	2
1.3 Operation	3
1.4 Connection and Installation	3
2. Parts Breakdown	7/8
3. Maintenance	4
3.1 General	4
3.2 Testing and Maintenance	4
4. Trouble Shooting	5
5. EC-Conformity Declaration	6
6. Technical Data/Specifications	9
7. Change of Clutch Spring	10
8. Torque Adjustment	11



Before starting operation of tool make sure to carefully read and follow operating instruction.

General Information

All DEPRAG MINIMAT-ULTRA screwdrivers can be used with or without lubrication. (Please refer to 3.2 Testing and Maintenance)

1. Operating Instruction

1.1 Safety Tips

- The drive spindle of the screwdriver can be used on both sides. The side of drive spindle which is not in use must be covered with safety cap 349100 always.
- The tool is not insulated to protect an electrical power surge.
- It is not recommended to use this tool in explosive hazardous environments.
- Do not push the start button when connecting the air to avoid starting of the screwdriver.
- Injury is possible, if the driver reacts with an unexpected motion or is damaged.
- During any maintenance or repair work, or when changing bits, the tool must be disconnected from the air supply.
- During any maintenance or repair work, a clean working surface is recommended. Also, it is not recommended to either eat or smoke during repair or maintenance.
- Unless otherwise requested the driver is preset to max. torque with the strongest clutch spring.

1.2 Application

Angle-Nutrunners are designed for the use in tight space conditions.

1.3 Operation

By pushing the start button the screwdriver starts with its high speed. With increasing torque the screwdriver reduces to its lower speed. The screwdriver switches-off after achieving of the pre-set torque. With releasing the start button the screwdriver is ready for the next cycle.

1.4 Connection and Installation

- Blow out air hose before connecting it to the tool.
- Connect the MINIMAT-ULTRA Screwdriver Spindle as follows:
 - a) If used with lubrication, connect driver to Maintenance Unit, consisting of Filter, Regulator and Lubricator.
 - b) If used without lubrication, connect driver to Maintenance Unit, consisting of Filter and Regulator.
- The required I.D. of pressure hose is 10 mm (1/4"). Please make sure, that the pressure hose length does not exceed 2 meters (6,6 ft.)
- The air pressure should be 90 PSI (6,3 bar). A pressure below 90 PSI reduces tool performance; a pressure above 90 PSI increases wear and tear on the tool.

In regards to air-quality according to ISO8573-1, we recommend:

	Class	Residue of Oil Content mg/m ³	Residue of Dust μ mg/m ³		Residue of Water DTP g/m ³	
Lubricated Air	4	5	15	8	+3	6
Dry Air	3	1	5	5	-20	0,88

Attention:

Make sure the hoses allow unrestricted air flow; avoid bends, nicks, etc.

2. Spare Parts List

Spare part list see picture 1 (page 7/8)

Torque Range of individual clutch springs: (appx.)

Type 376-3223

Part	WireØ	Color	appx. Torque minimum	appx. Torque maximum
337322	4,0 mm	violet	30,0 Nm = 263 in.lbs.	80,0 Nm = 700 in.lbs.
328025	3,2 mm	blue	15,0 Nm = 131 in.lbs.	45,0 Nm = 525 in.lbs.
328026	2,6 mm	green	10,0 Nm = 87,5 in.lbs.	25,0 Nm = 219 in.lbs.

Type 376-0223

Part	WireØ	Color	Torque minimum	Torque maximum
328024	5,0 mm	black	15,0 Nm = 131 in.lbs.	40,0 Nm = 350 in.lbs.
337322	4,0 mm	violet	8,0 Nm = 70 in.lbs.	30,0 Nm = 263 in.lbs.
328025	3,2 mm	blue	5,0 Nm = 44 in.lbs.	10,0 Nm = 87,5 in.lbs.

All torque values are based on 90 PSI (6,3 bar) air pressure.

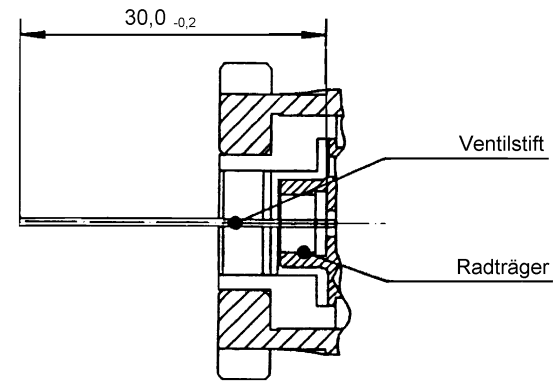

Picture 5: Actual size of Valve Pin (to be measured under air-pressure)



Attention:

When connecting to compressed air supply valve pin may be catapulted out which may cause serious injuries. When checking the actual size of the valve pin make sure to not hold the screwdriver towards yourself nor any other person.

Check the actual size only with compressed air connected!

Special Repair Tools

Wrench	11 mm AF	805491
Wrench	19 mm AF	800408
Wrench	41 mm AF	800414
Mounting Pin	(for key 326942)	460744
Adjustable Pin-Wrench		805080

Hole distance 9 - 60 mm, pin Ø 4 mm, for clamp bushing 345593.

8. Torque Adjustment (see picture 3)

1. Disconnect driver from air supply.
2. Turn sleeve 337477 until its long-hole is covering the adjustment-opening of the clutch bearing 337476 / 346538.
3. Turn the driver spindle of the angle-head until the adjustment-hole of the adjustment-nut 337674 is visible.
4. Push the adjustment tool 337691 into the hole of the adjustment nut 337674.
5. By turning the screwdriver in clockwise order the torque is reduced (-) and vice versa increased (+).

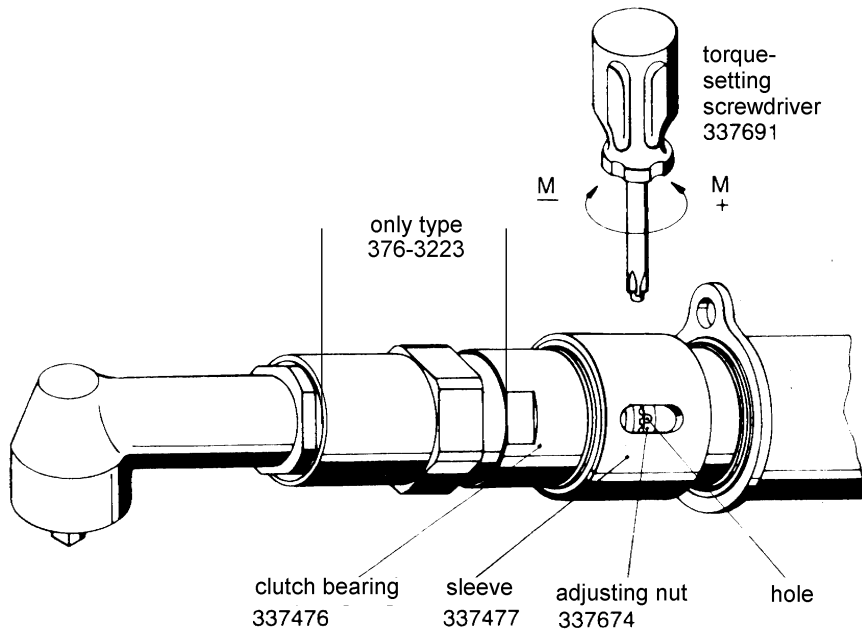

Picture 3: Torque Adjustment

3. Maintenance

3.1 General

Testing and maintenance can be provided by Operator; disassembly and re-assembly of the DEPRAG MINIMAT-ULTRA Screwdriver should be done by experience maintenance personnel. Incorrect assembly or disassembly can lead to injury of an operator and damage of the tool.

We would like to advise, that

3.2 Testing + Maintenance

The tool requires little maintenance. If the following service rules are observed, the tool will have a long life expectancy and will remain in a safe condition.

- Check tool on a regular basis for external damage.
- Check your maintenance until on a regular basis, make sure that sufficient oil is in the lubricator (if lubrication is used) and that the adjustment is correct. We recommend for your lubricator DEPRAGOL, part 790081 E. Oiling: approx. 1 - 2 drops per 1 m³ air consumption.
- If tool are being used with lubrication, we recommend to have tools tested and cleaned every 12 months (single shift).
- If tools are being used without lubrication, we recommend to have tools tested and cleaned every 6 months (single shift).
- After cleaning, the gearing parts have to be greased prior to re-assembly, preferably with Grease, part 807293.
- After assembly fill 2 – 3 drops of DEPRAGOL into the air inlet nipple.
- Exchange broken or worn bits and parts immediately, for they can cause injury to the Operator.

4. Trouble Shooting

Error	Reason	Solution
Screwdriver does not start	No air, Shut-Off valve is closed	Open Shut-Off valve
	Clutch is not engaged	Mount clutch correctly Refer to: Range- and exchange of clutch spring
Insufficient Power	Air pressure too low	Minimum air pressure should be 90 PSI for maximum performance
	Restriction in air hose	Remove bends or other restrictions
	Valve Pin too short	Check required length of valve pin according to picture 6. If needed, exchange valve pin.
	Hose I.D. is too small	Use required hose I.D.
	Vanes are worn	Exchange vanes
Driver does not shut-off or ratchets	Air pressure is too low for required torque value	Maintain air pressure of 90 PSI

7. Change of Clutch Spring (picture 2)

Prior to change of clutch spring, disconnect driver from air supply.

1. **Type 376-3223**

Clamp angle-nutrunner in vice, using tooth ring 337480, AF 46.

Type 376-0223

Clamp angle-nutrunner in vice, using screw joint 378816/1, AF 36.

- Unscrew clutch bearing 337476 / 346538 (SW 41, left-hand thread) with housing 337478.
- Take out clutch 374157 A complete.
- Unscrew adjustment nut 337674 by using 2 wrenches (AF 11, AF 19)
- Pull off lock ring 337673.
- Remove clutch spring, replace with new clutch spring and reassemble clutch in reverse order.
- Push clutch into the clutch bearing (make sure that hex drive of clutch shaft 331562 is engaging in hex drive of gearing 339420 /346511).
- Assemble screwdriver in reverse order. Make sure that the claws of pinion 339421 / spindle 335171 are engaged with the claws of clutch-claw-ring 331563.

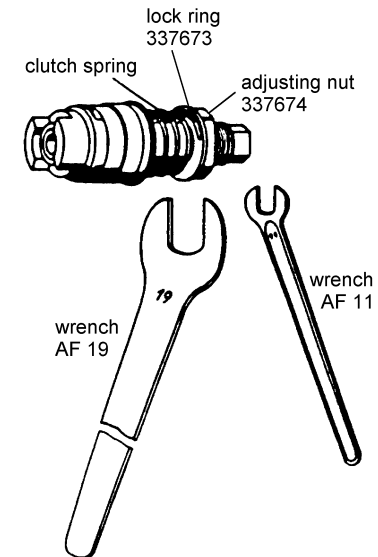

Picture 2: Change of Clutch Spring

6. Technical Data/Specifications

Technical Data:

Manufacturer: DEPRAG-SCHULZ GMBH & CO.
Address: Kurfürstenring 12 - 18 PO Box 1352
D-92224 Amberg D-92203 Amberg

Phone: 09621/371-0
Fax: 09621/371-120

Subsidiary: DEPRAG INC.
Address: 645 Hembry Street
Lewisville, TX 75057
Phone: (800) 4 DEPRAG = (800) 433-7724
Fax: (214) 221-8163

Series: DEPRAG MINIMAT-ULTRA Screwdriver

Model:	376-3223	376-0223
Order-no.	337668 C	356663 A
Length:	470 mm = 18,5 inches	446 = 17,6 inches
Square drive, make (DIN 3121)	G 3/8 i	
Drive (DIN 3126):	½ " female hex	
Weight:	2,5 kg = 5,52 lbs.	2,2 kg = 4,86 lbs
Air Pressure Requirement	6,3 bar = 90 PSI	
Hose I.D. Requirement:	10 mm I.D.	
Torque min. (Nm/in.lbs)	15 / 132	10 / 88
Soft pull-up max. (Nm/in.lbs)	80 / 708	40 / 354
Hard pull-up max. (Nm/in.lbs)	80 / 708	40 / 354
Speed (min⁻¹):	500 / 90	1100 / 160
Noise Level:	78 dB(A)	
Air Consumption:	0,6 m ³ /min	

5. EC-Conformity Declaration

EC-Conformity Declaration according to the EC-Machine-Guidelines 98/37/EC, Amendment IIA

We,

DEPRAG SCHULZ GMBH & CO.
PO Box 1352
D-92203 Amberg

hereby confirm, that the
the Screwdriver

376-3223
376-0223

conform to the following, relevant regulation:

- EC-Machine-Guidelines, Version 98/37/EC, Amendment No. 1 and No. 2.2.

Applicable Standard:

- EN 292

Amberg, 15.12. 2003

Dipl. Ing. (FH) A. Langig
Mr. Design Dept.

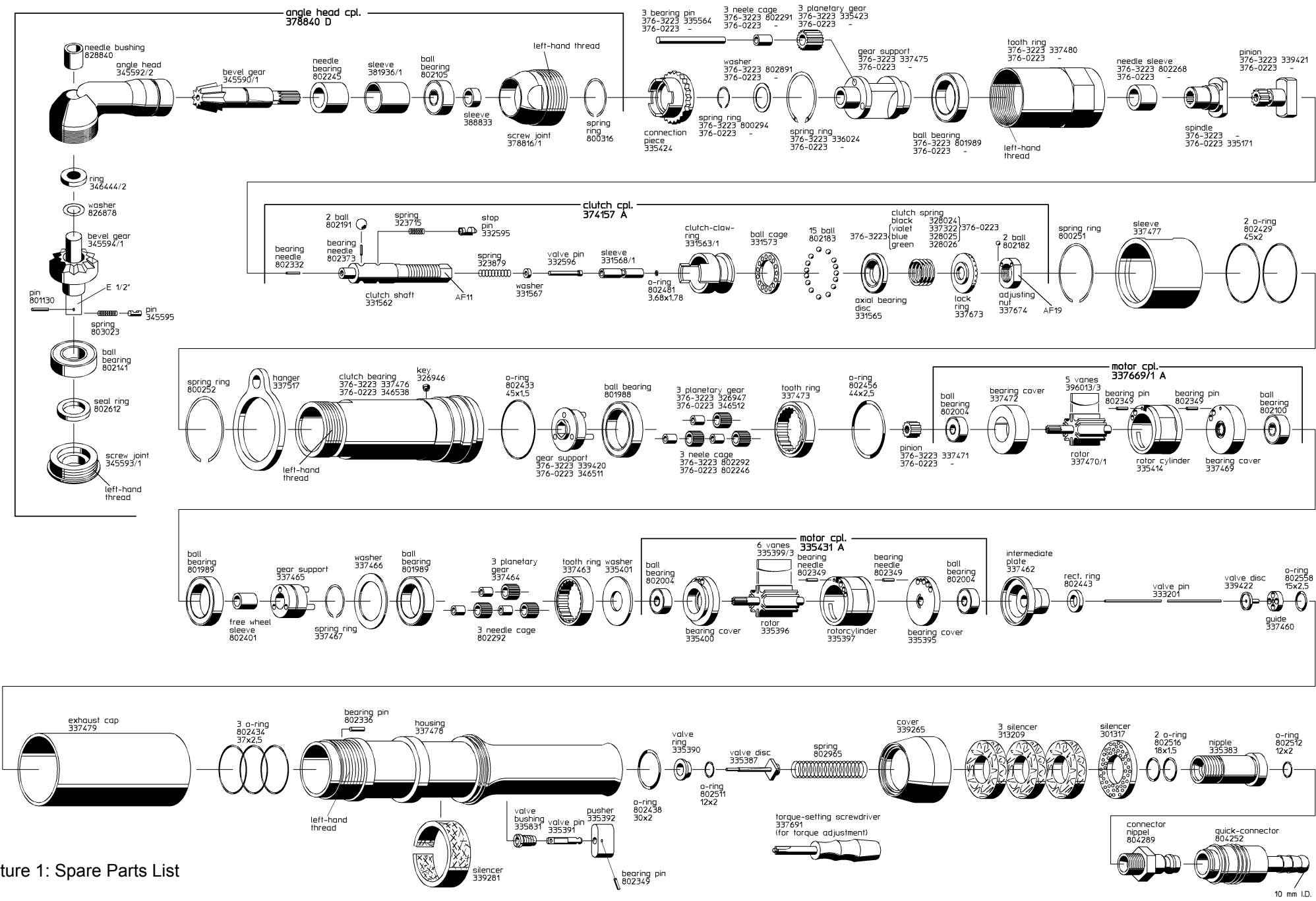

Picture 1: Spare Parts List
7/8

10 mm I.D.