

DEPRAG

Operating instructions

Pneumatic screwdriver

343-137U
343-237U

383901 A
383901 B

DEPRAG

DEPRAG SCHULZ GMBH u. CO.

Postfach 1352, D-92203 Amberg
Kurfürstenring 12-18, D-92224 Amberg
Telefon (09621) 371-0
Fax (09621) 371-120
Internet: <http://www.deprag.com>
e-mail: info@deprag.de

DEPRAG INC.

P.O. Box 1554 • Lewisville, Texas 75067 – 1554
645 Hembry Street • Lewisville, Texas 75057 – 4726
Phone (972) 221 – 8731 • FAX (972) 221 – 8163
TOLL FREE (800) 4 DEPRAG
Internet: <http://www.deprag.com>
e-mail: deprag@depragusa.com



CERTIFIED AS PER DIN EN ISO 9001

Dec-03 Technical alterations reserved

MINIMAT-ULTRA

Dear Customer:

Congratulations, you chose the enclosed tool from an extensive DEPRAG product line. This tool is the result of more than 60 years experience in the design and manufacturing of pneumatic tools for the industrial market. We offer a complete program of pneumatic tools, such as Drills, Tappers, Grinders, Screwdrivers, Impact Wrenches, Metal Working Tools and Hammers.

Please don't hesitate to call on us for all of your needs, from individual hand tools to the complete automated screwdriving cell. Our products offer solutions to any all requirements, which may be needed in the screwdriving sector.

We kindly ask, that you read these operating instructions carefully, so that you will be able to use this tool safely and for many years to come. If you need additional information, please contact your DEPRAG Representative or contact us direct at DEPRAG. We will be happy to answer any questions.

We hope you will be pleased with your new tool!

Table of Content

	Page
1. Operating Instruction	2
1.1 Connection + Installation	2
1.2 Operation	3
1.3 Range- and Exchange of Clutch Spring	3
1.4 Torque Adjustment	5
2. Parts Breakdown	7/8
3. Maintenance	6
3.1 General	6
3.2 Testing and Maintenance	6
4. Trouble Shooting	9
5. Safety Tips	10
6. EC-Conformity Declaration	11
7. All important data at a glance	12
8. Dismantling-Instructions	13
9. Assembly-Instructions	14

9. Assembly-Instructions

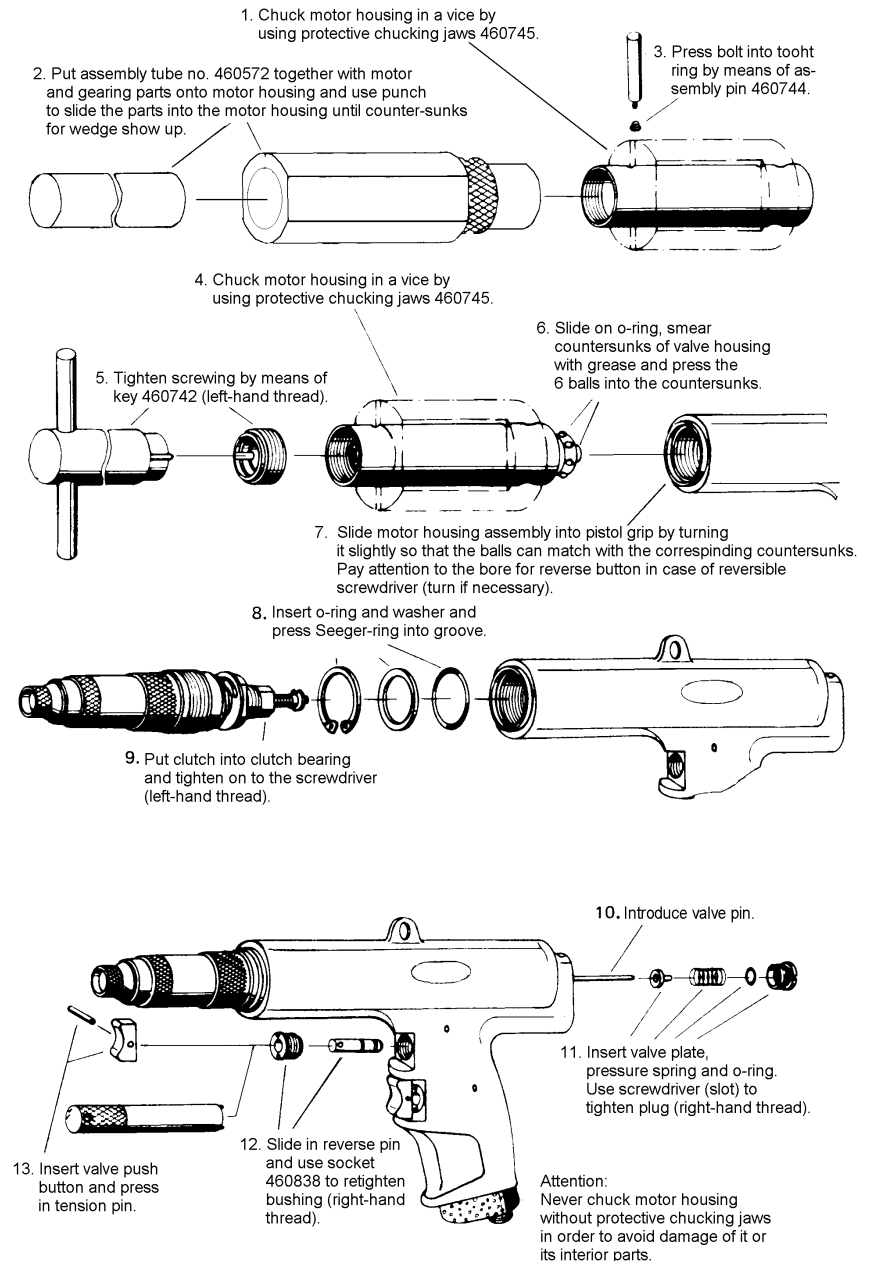

8. Dismantling-Instructions

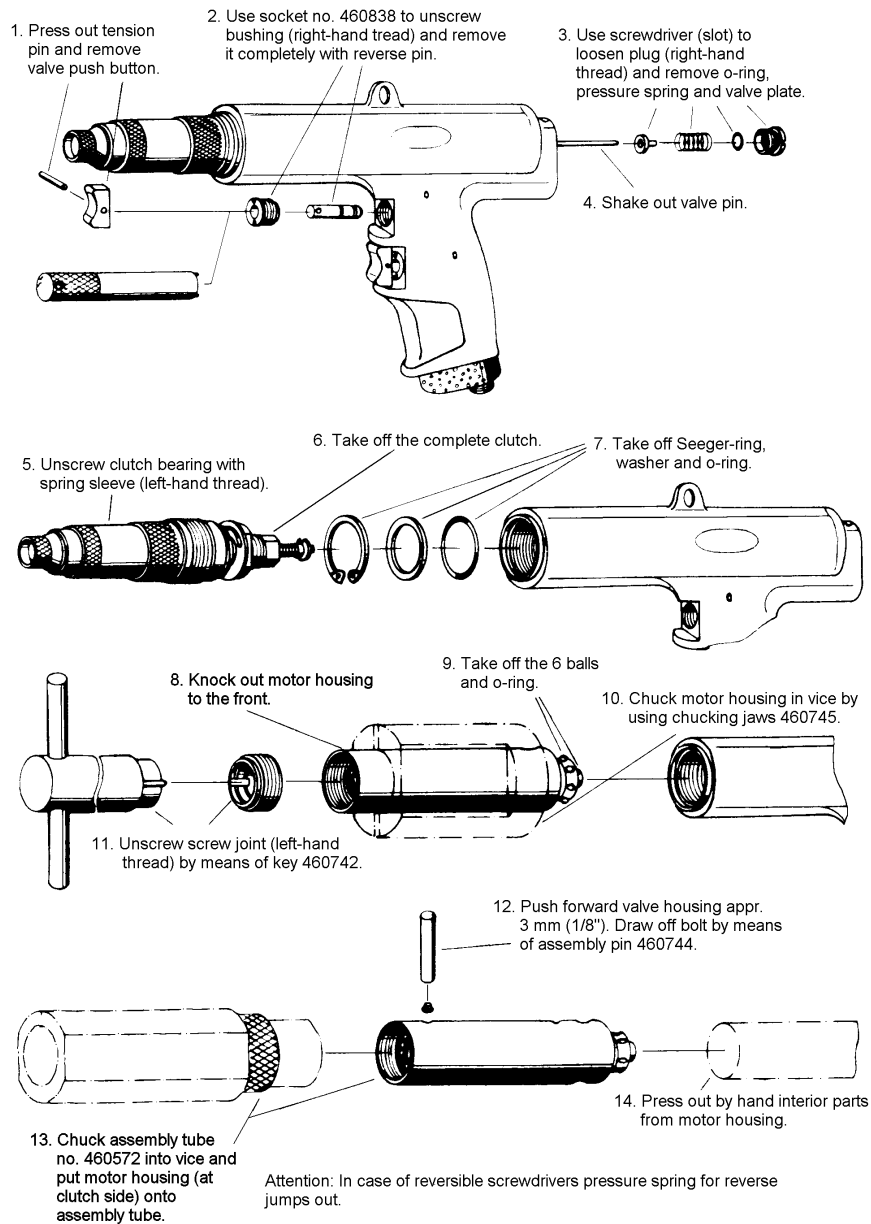

Before starting operation of tool make sure to carefully read and follow operating instruction.

General Information

All DEPRAG MINIMAT-ULTRA screwdrivers can be used with or without lubrication. (Please refer to 3.2 Testing and Maintenance) Oilfree operation could result in a loss of performance of up to 20 %.

1. Operating Instruction

1.1 Connection + Installation

- Blow out air hose before connecting it to the tool.
- connect the MINIMAT[®]-ULTRA Screwdriver as follows
 - a) if used with lubrication, connect driver to Maintenance Unit, consisting of Filter, Lubricator and Regulator.
 - b) if used without lubrication, connect driver to Maintenance Unit, consisting of Filter and Regulator.
- The required I.D. of pressure hose is 6 mm (1/4"). Please make sure, that the pressure hose length does not exceed 2 meters (6,6 ft.)
- Unless otherwise requested the driver is preset to max. torque with the strongest clutch spring.
- The air pressure should be 90 PSI (6,3 bar). A pressure below 90 PSI reduces tool performance, a pressure above 90 PSI increases wear and tear on the tool.

In regards to air-quality according to ISO 8573-1, we recommend:

	Class	Residue of Oil Content mg/m ³	Residue of Dust		Residue of Water	
			particle size µm	max. concentration mg/m ³	pressure dewpoint °C	max. concentration g/m ³
Lubricated Air	4	5	15	8	+3	6
Dry Air	3	1	5	5	-20	0,88

Attention:

Make sure the hoses allow unrestricted air flow; avoid bends, nicks, etc.

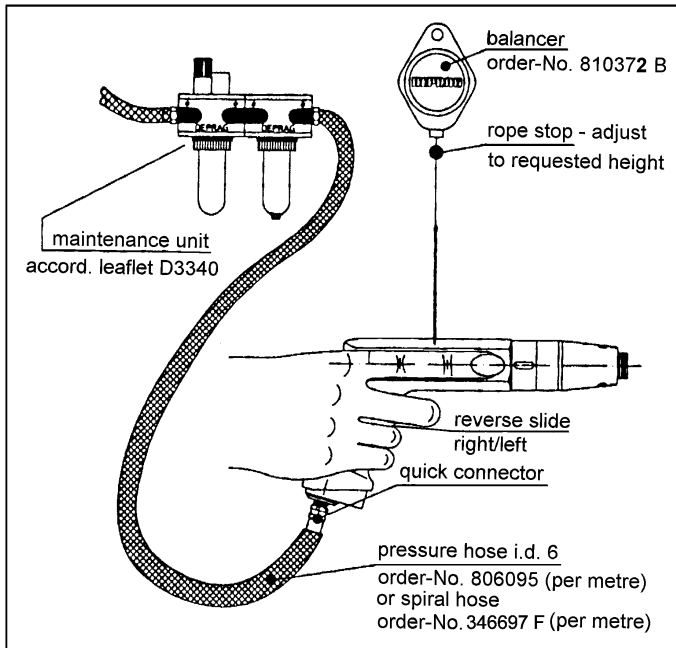

Picture 1: Connection of a DEPRAG MINIMAT-ULTRA Screwdriver

Operation with Finder and Magnetic Bits: (Picture 3)

To mount the finder (optional equipment)

- unscrew the spring sleeve (left hand thread)
- slide the finder into the spring sleeve, place spring into finder and then re-assemble the spring sleeve.

1.2 Operation

The operation of the DEPRAG MINIMAT-ULTRA Screwdriver is very simple. Grip the driver as shown on picture 1 and place the bit into the screw drive. As soon as you push the screwdriver it starts automatically and assembles the screw.

When the preset torque is reached, the clutch disengages and the driver stops. After lifting the driver it is ready for a new start.

When loosening screw, slide the reverse button to the left (see picture 2) before you start the driver.

7. All important data at a glance

Technical Data:

Manufacturer: DEPRAG-SCHULZ GMBH & CO.
 Address: Kurfürstenring 12 - 18 PO Box 1352
 D-92224 Amberg D-92203 Amberg
 Phone: 09621/371-0
 Fax: 09621/371-120
 Subsidiary: DEPRAG INC.
 Address: 645 Hembry Street
 Lewisville, TX 75057
 Phone: (800) 4 DEPRAG = (800) 433-7724
 Fax: (214) 221-8163

Model:	343-137U	343-137U
Order nr.	383901 A	383901 B
Length (cm / inches):	270 / 10,6	
Centre to side (mm / inches)	22 / 7/8	
Drive (inches):	¼ female hex	
Weight (kg / lbs.):	1,7 / 3,75	
Air Pressure Requirement (PSI):	90	
Hose I.D. Requirement (inches):	¼	
Torque min. (Nm / in.lbs)	2,0 / 18	2,0 / 18
Soft pull-up max. (Nm / in.lbs)	4,5 / 40	7,0 / 62
Hard pull-up max. (Nm / in.lbs)	5,5 / 49	8,0 / 71
speed (min⁻¹)	2300	1200
Noise Level (dB(A)):	66	
Air Consumption (cfm)	14	
Vibration (m/s²):	< 2,5	

6. EC-Conformity Declaration

EC-Conformity Declaration according to the EC-Machine-Guidelines 98/37/EC, Amendment IIA

We,

DEPRAG SCHULZ GMBH & CO.
PO Box 1352
D-92203 Amberg

hereby confirm, that the
Screwdriver

343-137U
343-237U

conform to the following, relevant regulation:

- EC-Machine-Guidelines, Version 98/37/EC, Amendment No. 1 and No. 2.2.

Applicable Standard:

- EN 292

Amberg, 11.12. 2003

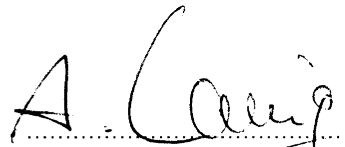
Dipl. Ing. (FH) A. Lanig
Mr. Design Dept.

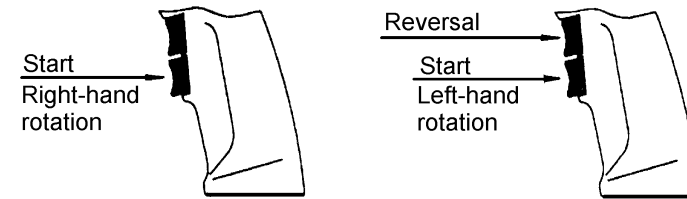

Picture 2: Reverse button as seen from hose-connection side.

The driver has a quick change chuck integrated. After the safety sleeve 327101 has been pulled toward the tip of the driver (see picture 4), the bit (6,3 mm = ¼" hex drive DIN 3126) can be removed or inserted. The spring sleeve has to be unscrewed (left-hand thread).

Before change of bits, disconnect the air. Otherwise the driver may start and possibly cause an injury. Please use only high quality ¼" hex bits.

Please note that an injury is possible:

- if the trigger is depressed and the bit is rotating.
- If the driver reacts with an unexpected motion or is damaged.

1.3 Range- and Exchange of Clutch Spring

The torque range of the DEPRAG MINIMAT[®]-ULTRA Screwdriver is adjustable. Please see a listing for the torque ranges of the color coded springs below:

Torque Range of individual clutch springs:

Part	WireÆ	Color	Torque minimum	Torque maximum
328025	3,2 mm	blue	2,0 Nm = 18 in.lbs.	8,0 Nm = 71 in.lbs.
328026	2,5 mm	green	1,0 Nm = 9 in.lbs.	4,0 Nm = 35 in.lbs.
328027	2,0 mm	red	1,0 Nm = 9 in.lbs.	3,0 Nm = 26 in.lbs.

All torque values are based on 90 PSI (6,3 bar) air pressure.

Attention:

Operate clutch only in specified range with correct clutch spring mounted!

Change of Clutch Spring (Picture 3)

Prior to change of clutch spring, disconnect driver from air supply.

1. Unscrew clutch bearing 327100. (left hand thread)
2. Take out clutch 382707 A / B complete.

3. Hold hexagon with open wrench (standard equipment) and unscrew adjusting nut 327091 with open wrench 22 mm across flats. (right-hand thread).
4. Pull off lock ring 327090.
5. Remove clutch spring, replace with new clutch spring and reassemble clutch in reverse order.
6. Push clutch into the clutch bearing and tighten clutch bearing to the motor housing of the screwdriver. (left hand thread)

Attention:

The hex-drive of the clutch must engage with the hex-drive of the spindle.

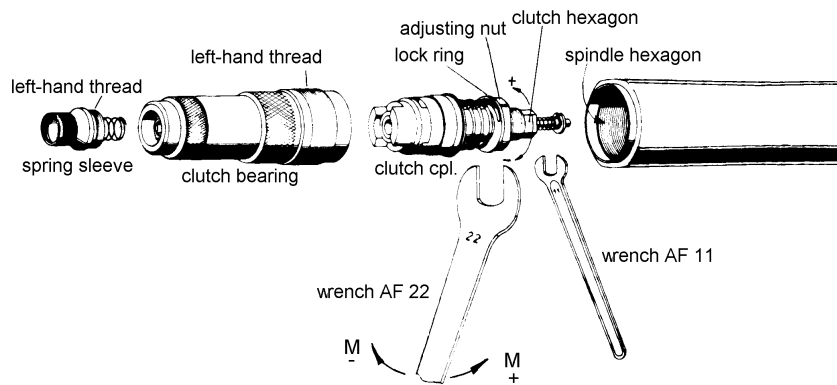

Picture 3: Change of Clutch Springs

1.4 Torque Adjustment

1. Unscrew clutch bearing 327100. (left-hand thread)
2. Take out clutch 382707 A / B complete.
3. Hold hexagon with open wrench 11 mm across flats (standard equipment) and unscrew adjusting nut 327091 with open wrench 22 mm across flats (right-hand thread). Right-hand rotation increases the torque. Left-hand rotation decreases the torque.
4. Push clutch into the clutch bearing 327100 and tighten clutch bearing to the motor housing of the screwdriver. (left-hand thread)

Attention:

The hex-drive of the clutch must engage with the hex-drive of the spindle.

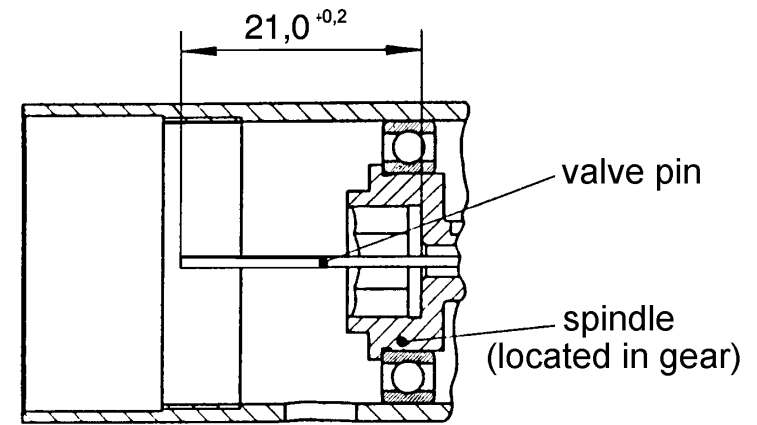

Picture 5: Actual size of Valve Pin



Warnung

Beim Ankoppeln der Druckluft kann der Ventilstift herausschießen und ernste Verletzungen verursachen. **Richten Sie beim Prüfen des Einbaumaßes den Schrauber nicht gegen sich oder andere Personen.**

Prüfen Sie das Einbaumaß nur mit angeschlossener Druckluft!

5. Safety Tips

The tool is not insulated to protect against an electrical power surge. It is not recommended to use this tool in explosive hazardous environments.

4. Trouble Shooting

Error:	Reason:	Solution:
Screwdriver does not start	No air, Shut-Off valve is closed	Open Shut-Off valve
Insufficient Power	Air pressure too low	Minimum air pressure should be 90 PSI for maximum performance
	restriction in air hose	Remove bends for other restrictions
	Valve Pin too short	Check required length of valve pin according to picture 5. If needed, exchange valve pin.
	Hose I.D. is too small	Use required hose I.D.
	Silencer clogged	Exchange silencer with new one
	Vanes are worn	Exchange vanes
Driver does not shut-off or ratchets	Air pressure is too low for required torque value	Maintain air pressure of 90 PSI
	Valve Pin is too long	Check length of valve pin, according to picture 5, either shorten or replace valve pin

2. Parts Breakdown

Parts Breakdown accord. Picture 4, Page 7/8

3. Maintenance

3.1 General

Testing and maintenance can be provided by Operator; disassembly and re-assembly of the DEPRAG MINIMAT-ULTRA Screwdriver should be done by experience maintenance personnel. Incorrect assembly or disassembly can lead to injury of an operator and damage of the tool.

We would like to advise, that

- during any maintenance or repair work, the tool must be disconnected from the air supply.
- during any maintenance or repair work, a clean working surface is recommended. Also, it is not recommended to either eat or smoke during repair or maintenance.

3.2 Testing + Maintenance

The tool requires little maintenance. If the following service rules are observed, the tool will have a long life expectancy and will remain in a safe condition.

- Check tool on a regular basis for external damage.
- Check your maintenance until on a regular basis, make sure that sufficient oil is in the lubricator (if lubrication is used) and that the adjustment is correct. We recommend for your lubricator DEPRAGOL, part 790081E. Oiling: approx. 1 - 2 drops per 1 m³ air consumption.
- If tool are being used with lubrication, we recommend to have tools tested and cleaned every 12 months (single shift).
- If tools are being used without lubrication, we recommend to have tools tested and cleaned every 6 months (single shift).
- After cleaning, the gearing parts have to be greased prior to re-assembly, preferably with Grease, part 807293.
- After assembly fill 2 – 3 drops of DEPRAGOL into the air inlet nipple.
- Exchange broken or worn bits and parts immediately, for they can cause injury to the Operator.

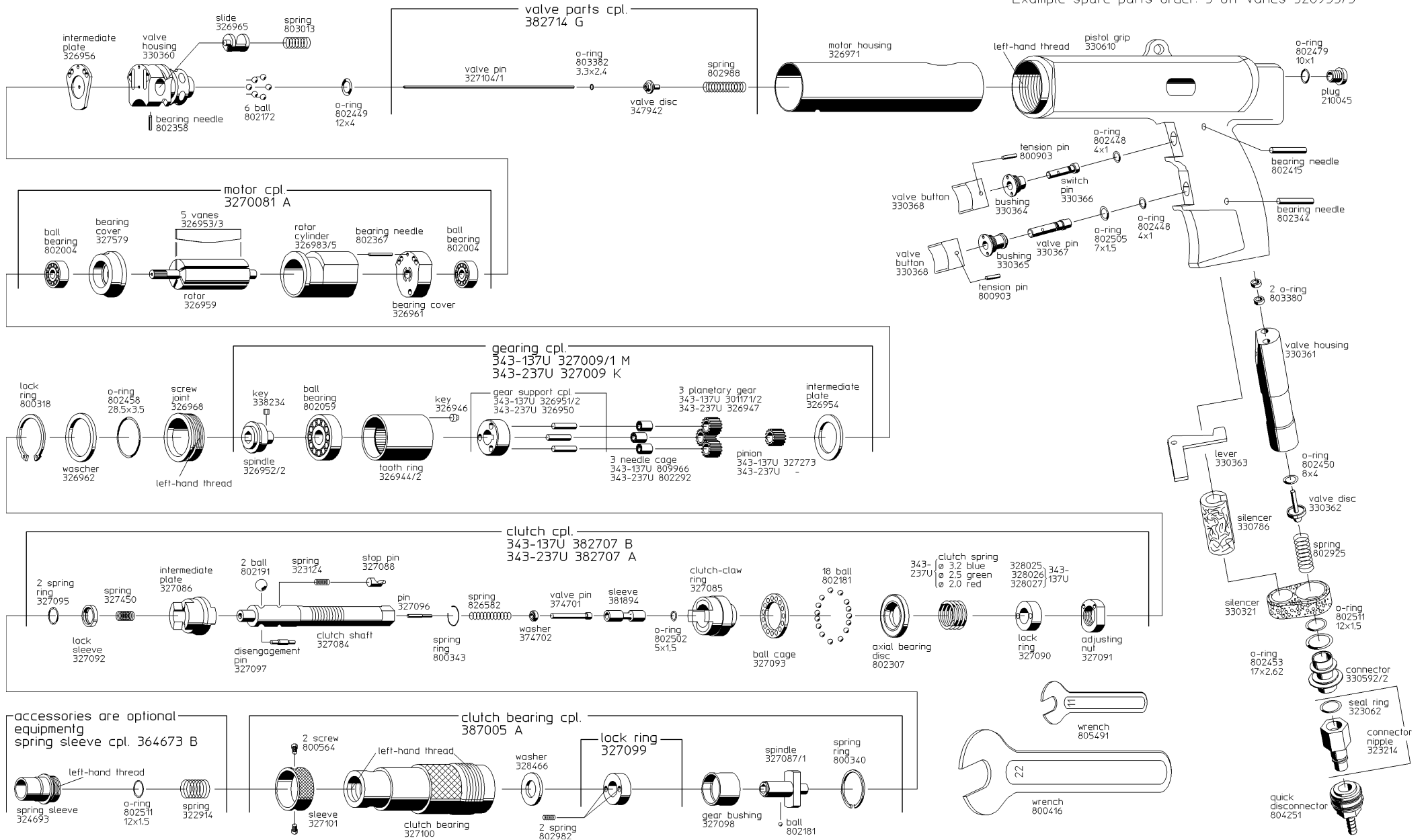

Picture 4: Parts Breakdown