

DEPRAG

Operating instructions

Pneumatic screwdriver

345C-338-31
345C-438-31

338382 C
338382 D

DEPRAG

DEPRAG SCHULZ GMBH u. CO.

Postfach 1352, D-92203 Amberg
Kurfürstenring 12-18, D-92224 Amberg
Telefon (09621) 371-0
Fax (09621) 371-120
Internet: <http://www.deprag.com>
e-mail: info@deprag.de

DEPRAG INC.

P.O. Box 1554 • Lewisville, Texas 75067 – 1554
645 Hembry Street • Lewisville, Texas 75057 – 4726
Phone (972) 221 – 8731 • FAX (972) 221 – 8163
TOLL FREE (800) 4 DEPRAG
Internet: <http://www.deprag.com>
e-mail: deprag@depragusa.com



CERTIFIED AS PER DIN EN ISO 9001

Dec-03 Technical alterations reserved

MINIMAT-ULTRA

Dear Customer:

Congratulations, you chose the enclosed tool from an extensive DEPRAG product line. This tool is the result of more than 60 years experience in the design and manufacturing of pneumatic tools for the industrial market. We offer a complete program of pneumatic tools, such as Drills, Tappers, Grinders, Screwdrivers, Impact Wrenches, Metal Working Tools and Hammers.

Please call us for all of your needs, from individual hand tools to the complete automated screwdriving cell. Our products offer solutions to any and all requirements, which are needed in the screwdriving sector.

We kindly ask, that you read these operating instructions carefully, so that you will be able to use this tool safely and for many years to come. If you need additional information, please contact your DEPRAG Representative or contact us direct at DEPRAG. We will be happy to answer any questions.

We hope you will be pleased with your new tool!

Content:	Page:
1. Operating Instruction	2
1.1 Safety Tips	2
1.2 Application	2
1.3 Range- and Exchange of Clutch Spring	3
1.4 Bit Change	4
1.5 Torque Adjustment	4
1.6 Connection, Installation and Operation	5
2. Parts Breakdown	9/10
3. Maintenance	11
3.1 General	11
3.2 Inspection and Maintenance	11
3.3 Assembly + Dis-Assembly	12
3.4 Special Repair Tools	12
4. Trouble Shooting	13
5. EC-Conformity Declarations/EC-Manufacturer Declaration	15
6. Technical Data/Specifications	16



Before starting operation of tool make sure to carefully read and follow operating instruction.

General Information

All DEPRAG MINIMAT-ULTRA screwdrivers can be used with or without lubrication. (Please refer to 3.2 Testing and Maintenance)

1. Operating Instruction

1.1 Safety Tips

- The tool is not insulated to protect an electrical power surge.
- It is not recommended to use this tool in explosive hazardous environments.
- Push - to - start - screwdriver! With pushing - in the bit the screwdriver will start immediately which could result in injuries.
- Injury is possible, if the driver reacts with an unexpected motion or is damaged.
- During any maintenance or repair work, or when changing bits, the tool must be disconnected from the air supply.
- During any maintenance or repair work, a clean working surface is recommended. Also, it is not recommended to either eat or smoke during repair or maintenance.

1.2 Application

Screwdriver Spindles are constructed for the stationary use in:

- Lever Operated Single Spindle Screwdriving Stations
- Construction Units
- Multi-Spindle Screwdriving Stations
- Robot End-Of-Arm Tooling
- X-Y-Z Screw-Assembly Stations

These Spindles assemble screws to torque and measure that torque more accurately than any subsequent testing method. They tighten and test the assembly in one operation.

Piezo Screwdriver- Spindles are equipped with an integrated Piezo Transducer, which can be used for calculation, documentation and statistical data evaluation. The transducer does not require outside current or re-calibration.

1.3 Range- and Exchange of Clutch Spring

The torque range of the DEPRAG MINIMAT-ULTRA Screwdriver is adjustable. Please see a listing for the ranges of the color coded springs below.

Torque range of individual Screwdriver Spindle:

Model	345C-338-31	345C-438-31
Torque Capacity:min.:	2,0 Nm = 17,7 in.lbs.	2,0 Nm = 17,7 in.lbs.
max. soft pull-up:	14,0 Nm = 124 in.lbs.	24,0 Nm = 212,5 in.lbs.
max. hard pull-up:	14,0 Nm = 124 in.lbs.	24,0 Nm = 212,5 in.lbs.

Torque Range of individual clutch springs: (appx.)

Part	WireØ	Color	Torque minimum	Torque maximum
328562	5,6 mm	white	8,0 Nm = 70,8 in.lbs.	24,0 Nm = 212,5 in.lbs.
328024	5,0 mm	black	5,0 Nm = 44,3 in.lbs.	18,0 Nm = 159,3 in.lbs.
328025	3,2 mm	blue	2,0 Nm = 17,7 in.lbs.	8,0 Nm = 70,8 in.lbs.
328026	2,5 mm	green	1,0 Nm = 8,85 in.lbs.	4,0 Nm = 35,4 in.lbs.

Operate clutch only in specified range with correct clutch spring mounted!

Disconnect driver from air supply.

1. Unscrew clutch bearing together with spring sleeve and quick change chuck (left-hand thread) by using wrench AF (32 mm).
2. Take out clutch complete.
3. Press torque setting screwdriver 337691 into the half-round bore of the safety ring and turn in clockwise direction, until the adjustment nut 337674 (see also picture 3).
4. Pull off lock ring 337673.
5. Remove clutch spring, replace with new clutch spring and re-assemble clutch in reverse order.
6. Push clutch into the clutch bearing. The valve pin have to guide in into the clutch shaft.

6. Technical Data/Specifications

Technical Data:

Manufacturer: DEPRAG-SCHULZ GMBH & CO.
 Address: Kurfürstenring 12 - 18 PO Box 1352
 D-92224 Amberg D-92203 Amberg
 Phone: 09621/371-0
 Fax: 09621/371-120

Subsidiary: DEPRAG INC.
 Address: 645 Hembry Street
 Lewisville, TX 75057
 Phone: (800) 4 DEPRAG = (800) 433-7724
 Fax: (214) 221-8163

Model:	345C-338-31	345C-438-31
Length (inches / mm):	12,03 / 305,5	
Diameter of motor housing (inches / mm)	14,17 / 36	
Drive (mm):	¼" female hex	
Weight (kg / lbs):	1,6 / 3,53	
Air Pressure Requirement (bar):	6,3	
Hose I.D. Requirement (mm):	10 I.D.	
Torque min. (Ncm)	2,0 – 14,0	2,0 – 24,0
(in.oz)	17,7 - 124	17,7 – 212,5
Speed (min ⁻¹):	800	400
Noise Level (dB(A)):	71	
Vibration (m/s ²)	< 2,5	
Air consumption (m ³ /min)	0,45	

5. EC-Conformity Declaration/EC-Manufacturer Declaration

EC-Declaration of Manufacturer
in accordance with the CE-Machine-Guideline 98/37/EG, appendix II B

DEPRAG SCHULZ GMBH u. CO.
P.O. Box 1352

92203 Amberg, Germany

declares, that the construction of

the Air Operated Piezo Screwdriver Spindle
DEPRAG MINIMAT-ULTRA

345C-338-31
345C-438-31

is appointed to the assembly with another machine and the start of operation of this other machine is prohibited until it is proved that it is in accordance with the CE-Machine-Guideline i.d. F.98/37/EG.

used standards
- EN 292

Amberg, 30.01. 2002

Dipl. Ing. (FH) A. Langig
Mr. Design Dept.

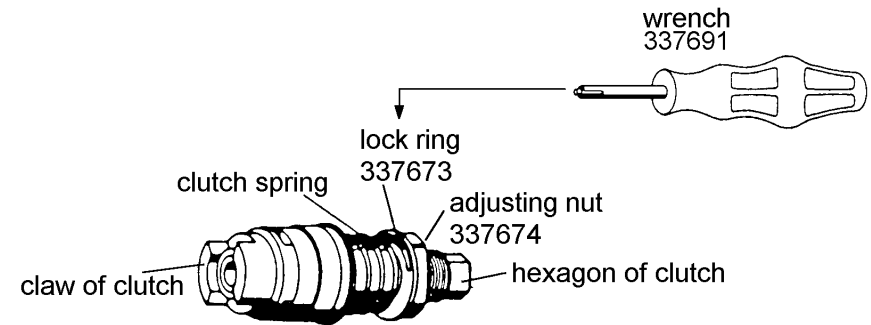

Picture 1: Change of clutch Spring

1.4 Change of Bits

Attention:

Before exchange of bits, clutch bearing has to be in place and driver needs to be disconnected from air supply.

To change bits, refer to picture Nr. 2:

1. Unscrew the spring sleeve (left hand thread). This is only necessary if a finder is mounted.
2. Pull the lock sleeve forward 331569, the bit (6,3mm = 1/4" hex drive) can now be removed or inserted.

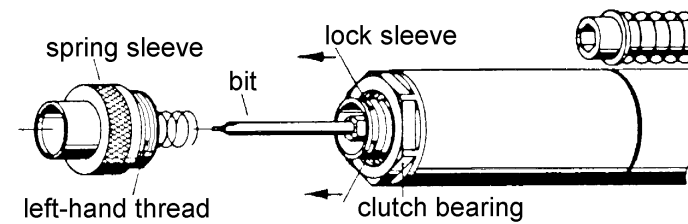

Picture 2: Change of Bits

1.5 Torque Adjustment (s. also Picture 1)

1. Disconnect screwdriver from air supply.
2. Press torque-setting-screwdriver through the opening of the clutch housing into one of the half-round bore. (If necessary, turn clutch with bit)
3. By turning the screwdriver in clockwise direction, the torque is reduced and by turning it counter-clockwise, the torque is increased.

Attention:

The hex of the clutch (AF 11) must engage in the hex of the spindle. Check for a push - to - start stroke of 2,5 mm on spindle on quick change chuck.

1.6 Connection, Installation and Operation

- Blow out air hose before connecting it to the tool.
- Connect the MINIMAT-ULTRA Screwdriver Spindle as follows:
 - a) If used with lubrication, connect driver to Maintenance Unit, consisting of Filter, Regulator and Lubricator.
 - b) If used without lubrication, connect driver to Maintenance Unit, consisting of Filter and Regulator.
- The required I.D. of pressure hose is 6 mm (1/4 "). Please make sure, that the pressure hose length does not exceed 2 meters (6,6 ft.)
- strongest clutch spring.
- The air pressure should be 90 PSI (6,3 bar). A pressure below 90 PSI reduces tool performance, a pressure above 90 PSI increases wear and tear on the tool.

In regards to air-quality according to ISO 8573-1, we recommend:

	Class	Residue of Oil Content mg/m ³	Residue of Dust		Residue of Water	
			particle size µm	max. concentration mg/m ³	pressure dewpoint °C	max. concentration g/m ³
Lubricated Air	4	5	15	8	+3	6
Dry Air	3	1	5	5	-20	0,88

Attention:

Make sure the hoses allow unrestricted air flow. avoid bends, nicks, etc.

These Spindles assemble screws to torque and measure that torque more accurately than any subsequent testing method. They tighten and test the assembly in one operation.

Piezo Screwdriver- Spindles are equipped with an integrated Piezo Transducer, which can be used for calculation, documentation and statistical data evaluation. The transducer does not require outside current or re-calibration.

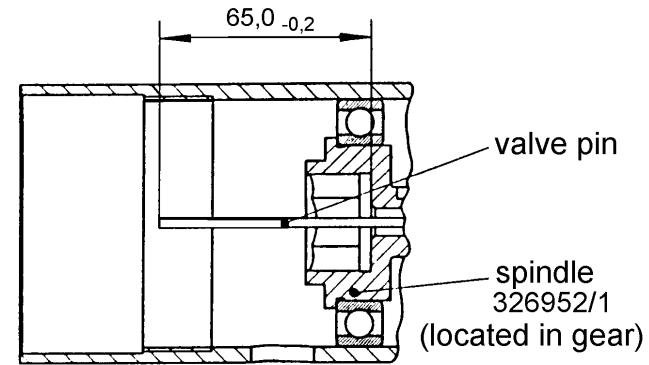

Picture 5: Actual size of Valve Pin



Attention:

When connecting to compressed air supply valve pin may be catapulted out which may cause serious injuries. When checking the actual size of the valve pin make sure to not hold the screwdriver towards yourself nor any other person.

Check the actual size only with compressed air connected!

4. Trouble Shooting

Error	Reason	Solution
Screwdriver does not start	No air, Shut-Off valve is closed	Open Shut-Off valve
	Clutch is not engaged	Mount clutch correctly Refer to: Range- and exchange of clutch spring
Insufficient Power	Air pressure too low	Minimum air pressure should be 90 PSI for maximum performance
	Restriction in air hose	Remove bends or other restrictions
	Valve Pin too short	Check required length of valve pin according to picture 5. If needed, exchange valve pin.
	Hose I.D. is too small	Use required hose I.D.
	Screen Support clogged	Clean screen support or exchange with new one
	Vanes are worn	Exchange vanes
Driver does not shut-off or ratchets	Air pressure is too low for required torque value	Maintain air pressure of 90 PSI
	Valve Pin is too long	Check length of valve pin, either shorten or replace valve pin (picture 5)
No Measuring Value	Broken Cable or Cable Plug is damaged	Replace Cable (see installation tips)
	Defective Piezo Cell (external damage)	Send Driver for Repair to DEPRAG

Installation:

The installation and connection of the Piezo Spindle requires the following steps:

1. Disconnect screwdriver from airsupply.
2. Adjust clutch to required torque setting (see 1.3/1.5)
3. Install Piezo spindle according to picture 3. If several Spindles are being installed, refer to the screwdriver arrangement on construction sheet 342217 (if you do not have this construction sheet, please call us)
4. Connect main air hose (3/8" I.D. Hose part 806096 - specify length).
5. Connect pneumatic function control hose (3mm I.D. Hose part 806107 specify length). This function control is under pressure of 2,5 bar during actual screw-driving. **If the function control is not needed, the port has to be closed, otherwise there is a loss of power of about 15 %.**
6. Connect Piezo-Transducer with connector cable to the DEPRAG display monitor.

Needed Equipment for Piezo-Transducer-Connection:

Connector Cable 1 meter (for driver to monitor) part 810629
 Extension Cable 5 meter part 810675
 Connector Plug (for connector cable/extension cable part 810676

7. Load calibration value into monitor (3 digit number, for example 298 located at clutch housing flange of screwdriver spindle).

Attention:

- Do not mount or clamp driver above the clutch bearing, otherwise the measuring value will change!
- Do not mount any other parts (i.e. PE Switch, etc.) above the clutch bearing to the spindle (measuring error)!
- Alignment-deviations of screwdriver- and bit-axis may influence the torque reading.
- Strong vibrations during measuring (for example uncushioned pneum. cylinders) may influence the torque readings.

The screwdriver will start when start-stroke of 2,5 mm is activated.

Please make sure not to exceed the driver stroke of 25 mm during screwdriving.

The noise level of 71 dB(A) can be further reduced, when an exhaust connection with connected Filter/Silencer is used.

Picture 3: Installation Tips for Piezo Spindle

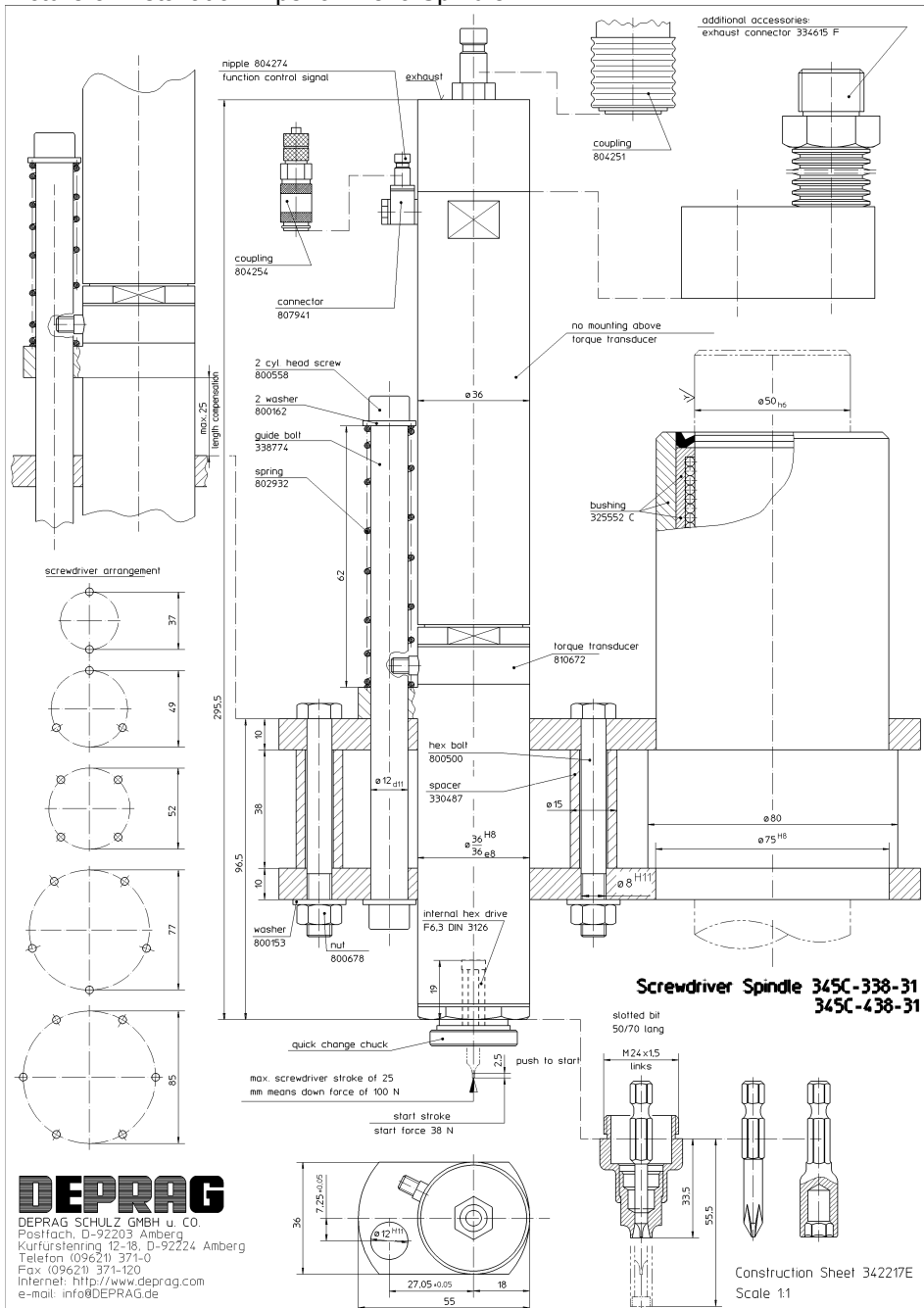

DEPRAG
 DEPRAG SCHULZ GMBH u. CO.
 Postfach, D-92203 Amberg
 Kurfürstenring 12-18, D-92224 Amberg
 Telefon (09621) 371-0
 Fax (09621) 374-120
 Internet: http://www.deprag.com
 e-mail: info@DEPRAG.de

3.3 Assembly and Dis-Assembly

The Dis-Assembly of the screwdriver Spindle should be made in the following sequence:

1. Disconnect screwdriver from airsupply.
2. Unscrew clutch bearing, spring sleeve and quick change chuck with wrench AF 32. (left-hand thread)
3. Take-out clutch.
4. Unscrew hex head screw 800558 with allen key AF 6 (right-hand thread) and pull-out guide bolt 338774.
5. Take-off function control port by unscrewing connector screw 801163. (AF 7, right-hand thread)
6. Unscrew nipple 323214 with wrench AF 17. (right-hand thread)
7. Turn-in plug 327598 with allen key AF 6 (through nipple 802784) by 2 rotations. (right-hand thread)
8. Unscrew nipple 802784 with wrench AF 17. (right-hand thread)
9. Pull-off sleeve 339768 and silencers.
10. Slide wrench AF 32, 4 mm thick, over clamp screw and unscrew motor housing 338757 with 2nd wrench AF 32. (left-hand thread)

Attention:

Never clamp screwdriver on motor housing 338757 or flange of clutch housing to avoid damage to internal parts and there from resalting incorrect torque readings.

11. Push valve housing 328177 approx. 3 mm towards the clutch side and pull-out key 326946 with mounting pin 460744.
12. Clamp mounting tube 460572 into vice and hold motor housing 338757 (with clutch side) onto mounting tube:
13. Push motor- and gearing parts into the mounting tube 460572 with plunger 461135. Motor- and gearing parts can be pushed-out of the motor housing (towards the clutch side) by using a suitable plunger (with out mounting tube).

Attention:

Motor- and gearing parts can get damaged if it falls down

Assembly has to be done vice versa.

3. Maintenance

3.1 General

Inspection and maintenance can be done by Operator, disassembly and re-assembly of the DEPRAG MINIMAT-ULTRA Screwdriver Spindle should be done by experienced maintenance personnel. Incorrect assembly or disassembly can lead to injury of an operator and damage of the tool.

We would like to advise, that

- during any maintenance or repair work, the tool must be disconnected from the air supply.
- during any maintenance or repair work, a clean working surface is recommended. Also, it is not recommended to either eat or smoke during repair or maintenance.

3.2 Inspection and Maintenance

The tool requires little maintenance. If the following service rules are observed, the tool will have a long life and will remain in a safe condition.

- Check tool on a regular basis for external damage.
- Check your maintenance until on a regular basis, make sure that sufficient oil is in the lubricator (if lubrication is used) and that the adjustment is correct. We recommend for your lubricator DEPRAGOL, part 790081E. Oiling: approx. 1 - 2 drops per 1 m³ air consumption.
- If tool are being used with lubrication, we recommend to have tools tested and cleaned every 12 months (single shift).
- If tools are being used without lubrication, we recommend to have tools tested and cleaned every 6 months (single shift).
- After cleaning, the gearing parts have to be greased prior to re-assembly, preferably with Grease, part 807293.
- After assembly fill 2 – 3 drops of DEPRAGOL into the air inlet nipple.
- Exchange broken or worn bits and parts immediately, for they can cause injury to the Operator.

Connection-Possibilities of the Function Control

Use as air pressure outlet during screw-assembly:

- to control driver start and stop, as well shut-off control of clutch;
- as cycle counter of the complete process; each in connection with a PE-Switch or similar.

Use as air pressure inlet:

- if 6,3 bar (90 PSI) air pressure is given to the function control port, the driver starts rotating at about 15 % of its speed. This will simplify the engagement of bit/socket to fastener (for example when driving hex screws, nuts, etc.)

Use of an Exhaust Connector

An exhaust connector 334615 F (to be ordered separately) can be mounted as follows:

1. Disconnect screwdriver from air supply.
2. Unscrew sleeve 329768 (as described in 3.3 Disassembly/Assembly, point 5 - 8)
3. Slide silencers in connector 334634 as shown in picture 5.
4. Turn connector 334634 and exhaust hose in required position and fasten it with nipple 802784 as well as plug 327598 and nipple 804271.

Attention: Plug 327598 must be interlocked against nipple 804271.

2. Spare Parts Listing

Refer to Picture 4, page 9/10

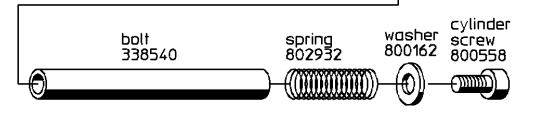
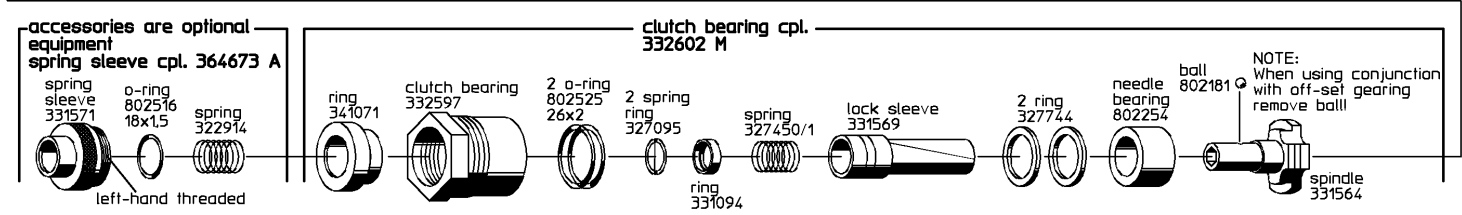
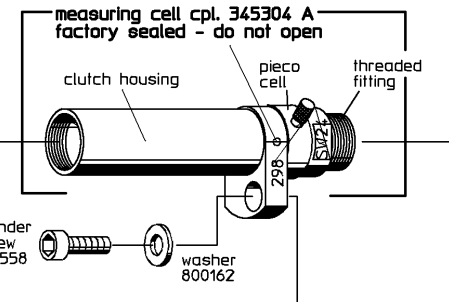
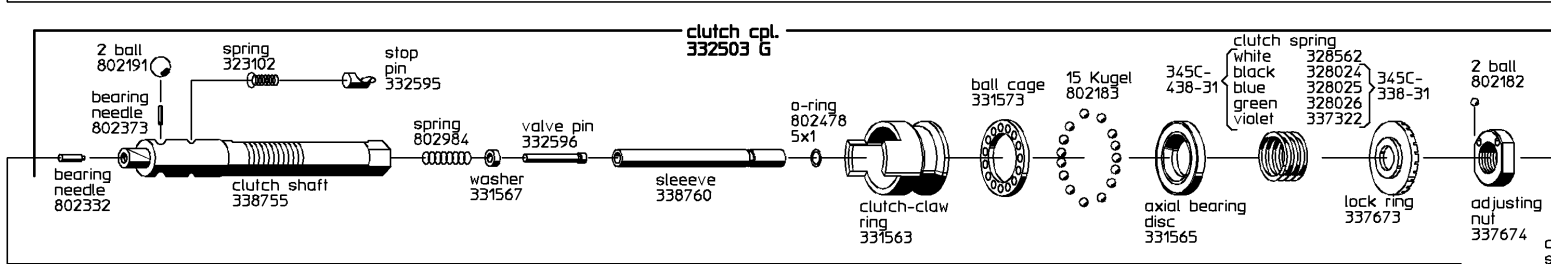
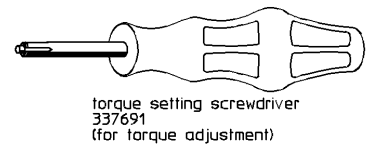
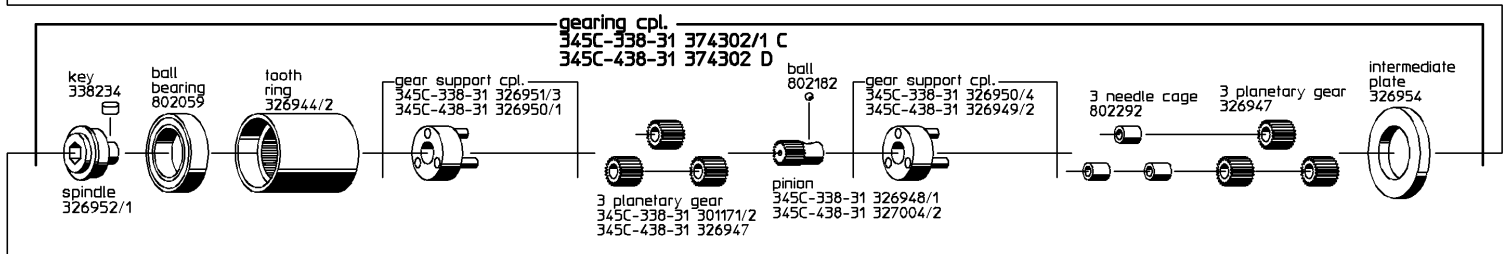
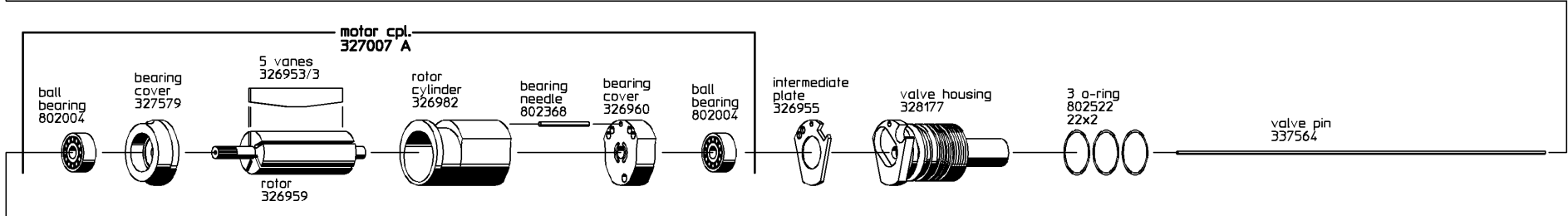
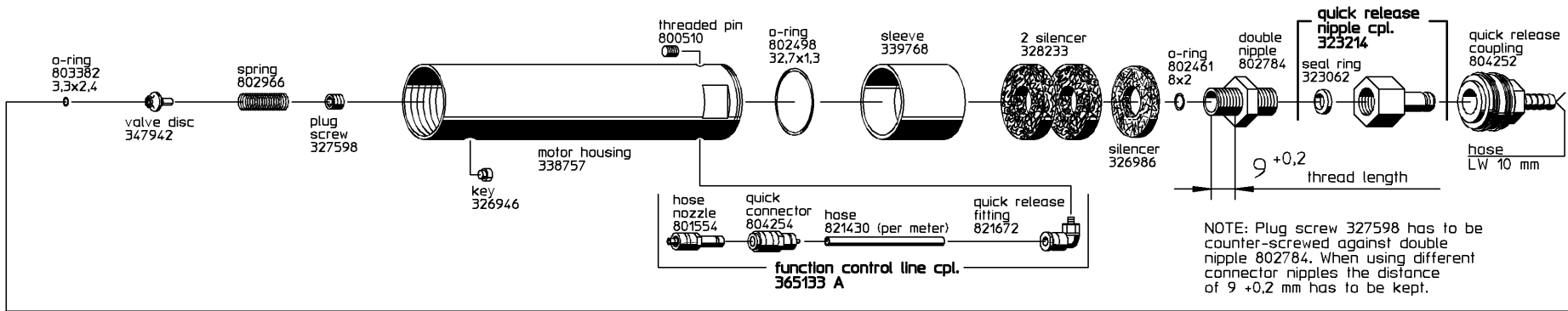

Example spare parts order: 5 off vanes 326953/3

Picture 4: Spare Parts Listing
9/10