

Operating Instruction Booklet

Torque Monitor

ME11-1	349977 A
ME11-2	349977 B
ME11-3	349977 C
ME11-4	349977 D

Table of Contents

1. General Information
 - 1.1 General Safety/Technical Information
 - 1.2 General Measurement/Technical Information
 - 1.3 Test of Tool Function Capability
 - 1.3.1 Tool Performance Index (Cm)
 - 1.3.2 Tool Performance Index (Cmk)
 - 1.4 Function of DME200
 - 1.4.1 Piezo Electric Effect
 - 1.4.2 Function of Piezo Measuring Transducers
 - 1.4.3 Function of Piezo Measuring Electronic
2. Front- and Back View
 - 2.1 Front View
 - 2.2 Back View
 - 2.3 Connections
3. Installation and Connection
 - 3.1 Connection of Cables
 - 3.1.1 Pin Configuration X1 (15 pole strip)
 - 3.1.2 Pin Configuration X1 (25 pole strip)
 - 3.2 Connection of PLC
 - 3.3 Connection of Foot-Switch
 - 3.4 Connection of Printer / PC
 - 3.5 Exchange of ME02-4 with ME11-4
4. Parameter Adjustment
 - 4.1 Operation of Menu Functions
 - 4.2 Menu Functions
5. Operation
 - 5.1 Single Measurements
 - 5.1.1 Start Signal by PLC
 - 5.1.2 Start Signal by Key-Pad
 - 5.2 Calculate Measurement Series
 - 5.2.1 Calculate Measurement Series by PLC
 - 5.2.2 Calculate Measurement Series by Key-Pad
6. Testing of integrated battery
7. Measurement Range
8. Time Diagram
 - 8.1 Start Single Measurement
 - 8.2 Calculate Measurement Series
 - 8.3 Error Removal
9. Upgrading Software Version
10. Technical Data/Specifications
11. Trouble Shooting
12. Conformity Declaration
13. Service Locations and Authorized Partners

1. GENERAL INFORMATION

1.1. General Safety/Technical Information

Please read carefully the provided Operating Instructions and adhere to all Safety Information, prior to use of this device.

All items which directly relate to the safety of the Operator and the error-free operation of the measuring instrument, are marked in the Operating Instructions with:



This measuring instrument has been designed and constructed for the sole purpose of monitoring Piezo-Transducers. The use of this instrument in any other way, is not acceptable. Furthermore DEPRAG is not liable for damages, resulting from the misuse of the instrument; the user alone is liable.

The correct use of the instrument includes compliance with all Operating-, Maintenance-, and Repair Instructions, which are considered an integral part.

The instrument can only be operated, maintained, and repaired by personnel who are familiar with the device and has been instructed about it's dangers.

All relevant accident-prevention instructions, as well as general acknowledged safety rules and workers protection regulations must be adhered to.

Arbitrary changes made to the device by the user will void the liability of the manufacturer for resulting damages.



Disconnect the unit from the power supply before performing maintenance.

1.2. General Measurement/Technical Information

When a start-signal is provided, the driver should not be running.

At that time the transducer should be free of external forces or vibrations (such as the pressure hose binding on the driver, or the distortion of the measuring platform resulting from incorrect installation).

After each start-signal, the charge amplifier will reset and perform a zero calibration. External forces, momentum, or vibration can distort the torque measurement.

If the instrument is used with open connections on channels CH1 CH4, a value of ≥ 0.00 will be displayed.

TERMINOLOGY

Measuring Value	:	Submitted torque from transducer
Calibration Value	:	The clamp load value of the transducer. This value is different for each spindle and must be keyed into the monitor.
Measurement Series and	:	The number of samples stored for average and standard deviation calculation. By start of a measurement series, the average torque and standard deviation for each channel are calculated and displayed.
Average Values number	:	Mean value is calculated from a specific number of previously stored values. $\bar{X} = \frac{1}{N} \sum_{i=1}^N X_i$
Standard Deviation specific	:	Standard deviation is calculated from a number of previously stored values. $s = \sqrt{\frac{\sum_{i=1}^N (X_i - \bar{X})^2}{N - 1}}$

In order to provide a high level of quality assurance and for you to be able to present the respective documents in case of an audit, we recommend to have your measuring devices re-calibrated once a year.

Concerning our torque measuring units and torque dynamometers as well as for a complete measuring series we would like to offer you to have these calibrated at the DEPRAG Amberg facilities.

Please do not hesitate to contact us in case you have questions.

1.3 Test of Tool Function Capability

Prior to the use of a tool for the mass production, it can be tested, if this tool fulfills the required demands with sufficient safety margin.

The goal of a Function Capability Test is to prove that:

- a) the tool to test conforms with recognized regulations. If no regulations are recognizable, then the tool does not have a defined capability. It is then not accepted to assign statistical calculated capability values to such a tool.
- b) the tool is capable to assemble parts within defined tolerances. The required proof can only be established using the recognized regulations, as shown under a).

The function capability test is a short-term test, with the goal to obtain exclusive machine-conditioned influences during the manufacturing process.

During the acquiring of sample readings, no disruption of the tool (system influence) should occur. (i.e. torque adjustment).

The test is based on the Gaussian distribution curve.

1.3.1 Tool Performance Index (C_m)

C_m = total specific torque tolerance of the connection : 6 Sigma (s). This index indicates the expanded scale of the torque values.

$$C_m = \frac{\text{Upper Limit} - \text{Lower Limit}}{6 * s}$$

1.3.2 Tool Performance Index (C_{mk})

C_{mk} is defined as the minimum of:

1.

or

2.
$$C_{mk} = \frac{\text{Average} - \text{Lower Limit}}{3 * s}$$

This index informs about the setting, as well as the expanded scale of the torque values.

The lower acceptable C_{mk} - value for a Driver is 1.33 [corresponds to the calculation of the

C_m - limit value of 4 sigma (s)].

C_m / C_{mk}	Limit Values	within the Limit Values	Fault Rate
0.30	$\pm s$	68.3	> 30%
0.70	$\pm 2s$	95.4	~ 5%
1.00	$\pm 3s$	99.7	3 ‰
1.33	$\pm 4s$	99.994	60 ppm
1.63	$\pm 4,891s$	99.9999	1 ppm
1.66	$\pm 5s$	99.99994	0.6 ppm
2.00	$\pm 6s$	99.9999998	$2 \cdot 10^{-9}$

The average torque should not deviate from the set value by more than 3%. A correct determination of the tool function index is not possible anymore.

1.4 Function of Measuring instrument ME11-1

The measuring instruments has been designed and constructed for the industrial measuring of piezo transducers.

1.4.1 Piezo Electric Effect

The positive and negative loads of the piezo-electric effective dielectric materials are distributed unsymmetrical. Because of the molecules respectively the crystals, the center of gravity of the positive loads does not subsidence with the negative loads. The piezo electric materials are electronically polarized. When those materials are deformed, the dipole moment changes. On account of those polarization changes, loads are being set free on the surface. Therefore, the piezo electric effect can be used to obtain the load size from the measurement, which causes the deformation. The freed load depends only on the deformation of the crystal and not on the speed or the acceleration of the deformation.

1.4.2 Function of Piezo Measuring Transducer

The Piezo-Spindles have piezo-quartz measuring cells integrated. Because of the preloading of the cell during manufacturing, the emitting electrical load (Coulomb) is determined. Since different cell sizes are available, the emitting electrical loads of the transducers are different.

The engraved calibration values on the transducer defines the emitted load (Coulomb) per Newton - Meter (Nm).

i.e. if a force of 1 Nm is put to the measuring cell, a load is emitted, which is defined by the calibration value.

Example for the calibration value: 172 pC / Nm

1 pico Coulomb = 0.000 000 000 001 C

1.4.3 Function of Measuring Electronic

The measuring electronic has a charge amplifier integrated, which transforms the emitted electrical load from the transducer into an electronic voltage. The voltage depends on the integrated capacitor, which is on the measuring input. I.e. at a range capacitor of 1000 pC, a load of 2000 pC is converted into 2 V. Each measuring range is rated to +/- 5V.

2 FRONT- AND REAR-VIEW

2.1 Front View

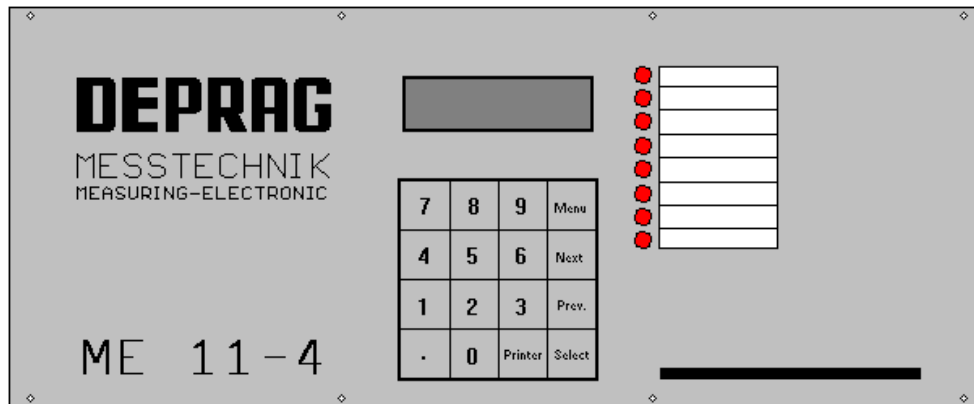

2.2 Rear View

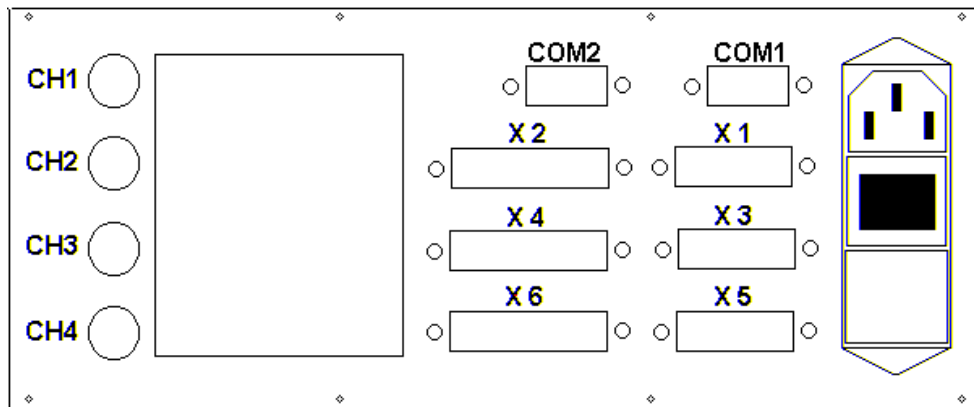

2.3 Connections

CH1 - CH4	:	BNC Connection Cable Channel 1 - 4 (Transducer)
COM1	:	Serial Port (Printer, PC)
COM2	:	not used
X1	:	Connection PLC / Foot-Switch / other
X2	:	Connection PLC
X3 - X6	:	not used

3 INSTALLATION AND CONNECTIONS

3.1 Connection of Cables

Connect Cable (810629) from driver to channel CH1, CH2...

Connect PLC or other Operating Instrument to Port X1 or X2
Connect Cable (357600A) for printer or PC to Port COM1.

The AC line-voltage can be changed by the voltage selector on the back of the monitor.



**The voltage selector must be adjusted to the correct voltage, otherwise the instrument will be damaged.
ONLY AFTER THE VOLTAGE HAS BEEN SELECTED, PLUG IN MAIN POWER CORD!**



If the instrument is on, do not connect or disconnect any of the ports CH1 - CH4 / X1 - X6. Always, turn device off first and disconnect the main power cable.



BEFORE OPENING HOUSING, DISCONNECT MAIN POWER CABLE!

3.1.1 Pin Configuration X1 (15 pole strip)

Pin Configuration X1		ME		PLC		Connection
		In	Out	In	Out	
1	←	Start Single Measurement	X		X	
9	←	Start Measuring Series Calculation	X		X	
2	←	Reset General Error/Channel Error	X		X	
10	←	Reset Overflow	X		X	
3	→	Monitor Ready		X	X	
11	→	Torque Failure General		X	X	
4	→	Measuring Series Calculation active	X		X	
12	→	Torque correct	X		X	
5	→	+24 V				ME
13	→	+24 V				ME
6	←	+24 V				PLC
14	←	+24 V				PLC
7	←	Ground Input				PLC
15	←	Ground Output				PLC
8	→	Ground				ME

3.1.2 Pin Configuration X2 (25 pole strip)

Pin Configuration X2		ME		PLC		Connection
		In	Out	IN	Out	
1	←	Start Single Measurement	X		X	
14	←	Start Measuring Series	X		X	
2	←	Reset Error	X		X	
15	←	Reset Overflow	X		X	
3	←	End Measurement Series	X		X	
16	←	not used				
4	←	not used				
17	←	not used				
5	→	Ready		X	X	
18	→	Torque Failure General		X	X	
6	→	Measuring Series Evaluation active	X		X	
19	→	Torque correct	X		X	
7	→	Error Channel 1	X		X	
20	→	Error Channel 2	X		X	
8	→	Error Channel 3	X		X	
21	→	Error Channel 4	X		X	
9	→	not used				
22	→	+24 V				ME
10	→	+24 V				ME
23	←	+24 V				PLC
11	←	+24 V				PLC
24	←	+24 V				PLC
12	←	Ground Input				PLC
25	←	Ground Output				PLC
13	→	Ground				ME

3.2 Connection of PLC

If the measuring instrument is to be connected to a PLC, connect PLC as shown at 2.1.1 or 2.1.2 to ports X1 or X2. The start-signal has to be changed from an impulse- to a permanent signal (see 4.1); if a PLC is controlling the Unit.

3.3 Connection of Operating Instruments / Foot-Switch

If the measuring instrument is not connected to a PLC, a special operating instrument (for example a foot-switch) is required for the use in automatic mode. Connect this operating instrument to port X1 or X2.

In this case, the signal has to be changed from an permanent- to a impulse signal (see 4.1)

3.4 Connection of Printer / PC

The measuring data can be sent through the serial port (COM1) to a printer or PC.

For the serial port, the following parameters apply:
 9600 Baud 8 Data Bits no parity 1 Stop Bit

Pin Configuration on the measuring instrument: (9 pole strip)
 Pin 2 = RXD Pin 3 = TXD Pin 5 = Signal Ground

Printer ND40 (810682A) can be connected to the torque monitor.
 The two DIP-Switches on the side have to be adjusted as follows:

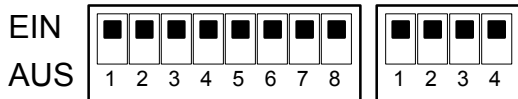

The printer can be switched on or off by using the PRINTER-button. A choice of "normal" and "not o.k." print mode is offered. (when in "not o.k." mode, the printer will print only measuring values which are out of the preset window)

An indication LED on the front plate shows the operating status.

If data transfer to a PC is required, a "TERMINAL" program is needed and the mode has to be changed to TERMINAL.

Dataformat:

Counter < 10.000

Counter	Value 1	Value 2	Value 3	Value 4
XXXX	← ±XXX.XX	← ±XXX.XX	← ±XXX.XX	← ±XXX.XX

Counter >= 10.000 – 30.000

Counter	Value 1	Value 2	Value 3	Value 4
XXXXX	← ±XXX.XX	← ±XXX.XX	← ±XXX.XX	← ±XXX.XX

3.5 Exchange of ME02-... with ME11-4

If a measuring instrument, Model# ME02-... is being replaced with the measuring instrument, Model# ME11-4, please note that the pin configuration of the 15 pole strip of port X1 is not compatible. The 15-pole pin-strip has to be re-wired as shown in paragraph 3.1.1!

Pin Configuration ME02-...		ME02-...		PLC	
		In	Out	In	Out
1	●				
	9				
2	●	X			X
	10		X	X	
3	●				
	11		X	X	
4	●	X			X
	12		X	X	
5	●		X	X	
	13		X	X	
6	●		X	X	
	14				
7	●		X	X	
	15				
8	●				

A single-channel evaluation can only be obtained over the 25-pole port X2.

4. PARAMETER ADJUSTMENT

4.1 Operation of Menu Functions

The parameter adjustment can be protected by the input of a password. If such a password protection is used, the password has to be input once the menu-key is pushed. If a wrong password is keyed, or if the PREV-key is pushed, the option to change the measurement parameter or system adjustment is locked. The password can be deleted by inputting "000000".

Any time a parameter adjustment is required, the measuring instrument has to be in the menu-mode, using the following steps:

1. Turn the measuring instrument on.
2. Push the menu-key to obtain the menu-mode.
3. Check for password.
4. The display shows

BASIC ADJUSTMENT SELECTION

To continue in the menu, please follow the description and diagram as shown on the next page. The following keys are necessary:

- PREV-Key => return to the previous menu point
- NEXT-Key => go to the next menu point
- SELECT-Key => go to a sub-menu within the current menu point and/or confirm a selection

When using the PREV-Key, system will at all times return to the previous menu point. The values in the selected menu point will not be changed.

4.2 MENU FUNCTIONS

BASIC ADJUSTMENT SELECTION	ME11-4 D VERSION 2.0
-----------------------------------	----------------------------

SELECT LANGUA GE	GERMAN ***** ****
	ENGLISH
	ITALIAN
	SPANISH

Select lanugage for display and printer.

SELECT UNIT	Nm ***** ****
	IN / LBS

Select measurement unit for display and printer.
1 Nm = 8.89 In/lbs

AMOUNT OFSCRE W- DRIVER SPINDLE S	1- CHANNE L ***** ****
	2- CHANNE L
	3- CHANNE L
	4- CHANNE L

Input amount of required measurement channels.
!
It is important not to input more channels as connections are available on the back of the measuring instrument!

PRINTER ADJUSTM ENT	NORMAL ***** *****
	NOT O.K. PRINTOU T
	TERMINA L

Select printout:
NORMAL : all values are printed
NOT O.K. : all NOT O.K.-values are printed
TERMINAL : all values are printed, except the header, special characters and the color designation of the printer. NOT O.K. – values will be indicated with „ * “.

SELECT/ CHANGE DATE	DD-MM- YY EC- FORMAT
	MM-DD- YY US- FORMAT

Select between either the european date-format or the US date-format:
 EC-FORMAT : DD.MM.YY
 US-FORMAT : MM-DD-YY

SELECT/ CHANGE DATE	HH:MM:S S EC- FORMAT
	HH:MM:S S AM US- FORMAT

Select between either the european time-format or the US date-format:
 EC-FORMAT : HH:MM:SS
 US-FORMAT : HH:MM:SS
 AM/PM

SELECT/ CHANGE START SIGNAL	PERMAN ENT ***** *****
	IMPULSE ***** *****

Permanent : The start-signal has to remain „on“ during the complete measurement operation.
 Impulse : To start operation, a short impulse signal is sufficient. The measuring instrument completes, the measurement automatically, if the PEAK- storage remains constant for 20 milli seconds.

SELECT/ CHANGE MEASUR EMENT SERIES	SERIES: 10	10 ... 100	Input the amount of the required cycles, to calculate the average torque and the standard deviation.
--	---------------	---------------	--

SELECT/ CHANGE CMK- CALCULA TION	OFF ***** *****
	ON

If ON, the Cm or Cmk-values are being calculated and displayed after each measurement series. If printer in turned on, those values will be also printed.

CHANGE PASSWO RD	PASSWO RD: []
------------------------	----------------------

A password eliminates that the system adjustment or parameter-adjustment will be changed by unauthorized personnel. To delete the password, input "000000".

MEASUREMEN T PARAMETERS	CHANNE L 1	CAL- VALUE: 200 PC/Nm	100 ... 1000	Measurement Parameter for Channel 1 Input the calibration value „ CAL-VALUE “. Use the keypad to input the calibration value, which is engraved on the flange of the Screwdriver Spindle to be connected. Input the set-value " SET-VALUE ". This set-value is needed for the calculation of the Cmk-value. For the required torque, input the permissable limit values " TORQUE-MIN " und " TORQUE -MAX " (Tolerance Window). Using the number-keys 0 - 9, input the torque-values dependency from the set-value.
		SET- VALUE : 0.0	0.0 ... 200. 0	
		TORQUE- MIN : 0.0 0-9 => -%	0.0 ... 200. 0	
		TORQUE- MAX : 0.0 0-9 => +%	0.0 ... 200. 0	

CHANNE L 2	CAL- VALUE: 200 PC/Nm	100 ... 1000	Measurement Parameter for Channel 2 Input the calibration value „ CAL-VALUE “. Use the keypad to input the calibration value, which is engraved on the flange of the Screwdriver Spindle to be connected. Input the set-value „ SET-VALUE “. This set-value is needed for the calculation of the Cmk-value. For the required torque, input the permissible limit values „ TORQUE-MIN “ und „ TORQUE -MAX “ (Tolerance Window). Using the number-keys 0 - 9, input the torque-values dependency from the set-value.
	SET- VALUE : 0.0	0.0 ... 200. 0	
	TORQUE- MIN : 0.0 0-9 => -%	0.0 ... 200. 0	
	TORQUE- MAX : 0.0 0-9 => +%	0.0 ... 200. 0	

CHANNE L 3	CAL- VALUE: 200 PC/Nm	100 ... 1000	Measurement Parameter for Channel 3 Input the calibration value „ CAL-VALUE “. Use the keypad to input the calibration value, which is engraved on the flange of the Screwdriver Spindle to be connected. Input the set-value „ SET-VALUE “. This set-value is needed for the calculation of the Cmk-value. For the required torque, input the permissible limit values „ TORQUE-MIN “ und „ TORQUE -MAX “ (Tolerance Window). Using the number-keys 0 - 9, input the torque-values dependency from the set-value.
	SET- VALUE : 0.0	0.0 ... 200. 0	
	TORQUE- MIN : 0.0 0-9 => -%	0.0 ... 200. 0	
	TORQUE- MAX : 0.0 0-9 => +%	0.0 ... 200. 0	

CHANNE L 4	CAL- VALUE: 200 PC/Nm	100 ... 1000	Measurement Parameter for Channel 4 Input the calibration value „ CAL-VALUE “. Use the keypad to input the calibration value, which is engraved on the flange of the Screwdriver Spindle to be connected. Input the set-value „ SET-VALUE “. This set-value is needed for the calculation of the Cmk-value. For the required torque, input the permissible limit values „ TORQUE-MIN “ und „ TORQUE -MAX “ (Tolerance Window). Using the number-keys 0 - 9, input the torque-values dependency from the set-value.
	SET- VALUE : 0.0	0.0 ... 200. 0	
	TORQUE- MIN : 0.0 0-9 => -%	0.0 ... 200. 0 0...9	
	TORQUE- MAX : 0.0 0-9 => +%	0.0 ... 200. 0 0...9	

Copy to
Channel?

1...4 The input values of one channel can be copied to other channels.
However, the „CAL-VALUE“ has to be input for each channel individually.

**OPERATING
MODE**

AUTOMA
TIC

**

Control the measuring instrument by one of its ports.

TEST

Control the measuring instrument by its keypad.
“1” = Measurement ON “2” =
Measurement OFF “4” = Statistics
Program

5. OPERATION

All parameters remain stored in the CMOS-RAM of the measuring instrument when the instrument is turned off. Therefore, it is not necessary to re-input data everytime the instrument is switched on. If changes to the input-data are required, input new parameters as shown in paragraph 4.

5.1 Single Measurement

Turn on measuring instrument.

5.1.1 Start Signal by PLC

To start single measurements apply the startsignal single measurement on the control connection and "Automatic Mode" should be selected. The Automatic LED will be on. The Automatic LED will turn off while the single measuring signal is on.



The start signal single measurement has to be applied prior to bit-engagement and spindle rotation of the driver and should only be removed once the assembly is completed.

After the start signal goes off, the torque values will be displayed.

PLC-programming

Example Simatic S5 : U start assembly
 = start single measurement
 UN ready for measurement
 = start screwdriver spindle

5.1.2 Start Signal by Key-Pad

To start single measurements adjust the operating mode to "Test Mode".

Key (1) = Start Single Measurement

Key (2) = End Single Measurement (in "permanent signal" mode). At impulse signal, the end of the measurement is recognized automatically.

5.2 MEASUREMENT SERIES CALCULATION

If the Cmk-calculation is ON, the instrument displays after each measurement series besides the average torque and standard deviation also the Cm and Cmk-values.

5.2.1 Measurement Series Calculation by PLC

To start measurement series calculation apply the signal measurement-series to the control connection. The operating mode should be in "Automatic Mode". For the calculation, the previous collected values from the menu-point: "SELECT/CHANGE MEASURING SERIES" are used.



All values have to have the same prefix. If the prefix of any channel is changed, all values for the statistical process will be deleted.

5.2.2 Measurement Series Calculation by Key-Pad

To start measurement series calculation, adjust the operating mode to "Test Mode".

Key (4) = Calculate Average and Standard Deviation

6. TESTING OF INTEGRATED BATTERY

If the battery (821321) shows deminishing strength, the following message will be displayed when turning the measurement instrument on:

BATTERY EMPTY; RECHECK PARAMETERS

Push key "SELECT"

The following values will be lost when battery is empty:

- Limit Values
- Calibration Values
- Set-Values
- Number of Screwdriver Spindles
- Signal Change
- Printer on/off
- Printer normal/not o.k./terminal
- Language
- Measurement Unit
- Password
- Date
- Time

As long as the battery is not replaced, those values have to be re-entered every time the measuring instrument is turned on.

The life span of a battery is between 3 - 5 years.

7. MEASUREMENT RANGE

The measurement instrument has six different measurement ranges. Those ranges depend on the upper limit- (TORQUE-MAX) and calibration value (CAL-VALUE) which were input for each corresponding channel.

Measuring Range 1: 100 pC
Measuring Range 2: 500 pC
Measuring Range 3: 1000 pC
Measuring Range 4: 5000 pC
Measuring Range 5: 10000 pC
Measuring Range 6: 50000 pC

Calculation: TORQUE-MAX * CAL-VALUE = MEASURING RANGE

Example 1 - Range 4: $3.4 \text{ Nm} * 292 \text{ pC/Nm} = 992.8 \text{ pC}$
 $1000 \text{ pC} * 0.9 = 900 \text{ pC}$
 $\rightarrow 992.8 > 1000 * 0.9 \rightarrow \text{MB 5}$

Example 2 - Range 4: $0.6 \text{ Nm} * 292 \text{ pC/Nm} = 175.8 \text{ pC}$
 $500 \text{ pC} * 0.9 = 450 \text{ pC}$
 $\rightarrow 175.8 < 500 * 0.9 \rightarrow \text{MB 2}$

If the measuring value is larger than the measuring range, the following message will be displayed:

MEASURING VALUE TOO LARGE

8. TIME DIAGRAMS

8.1 Start Single-Measurement

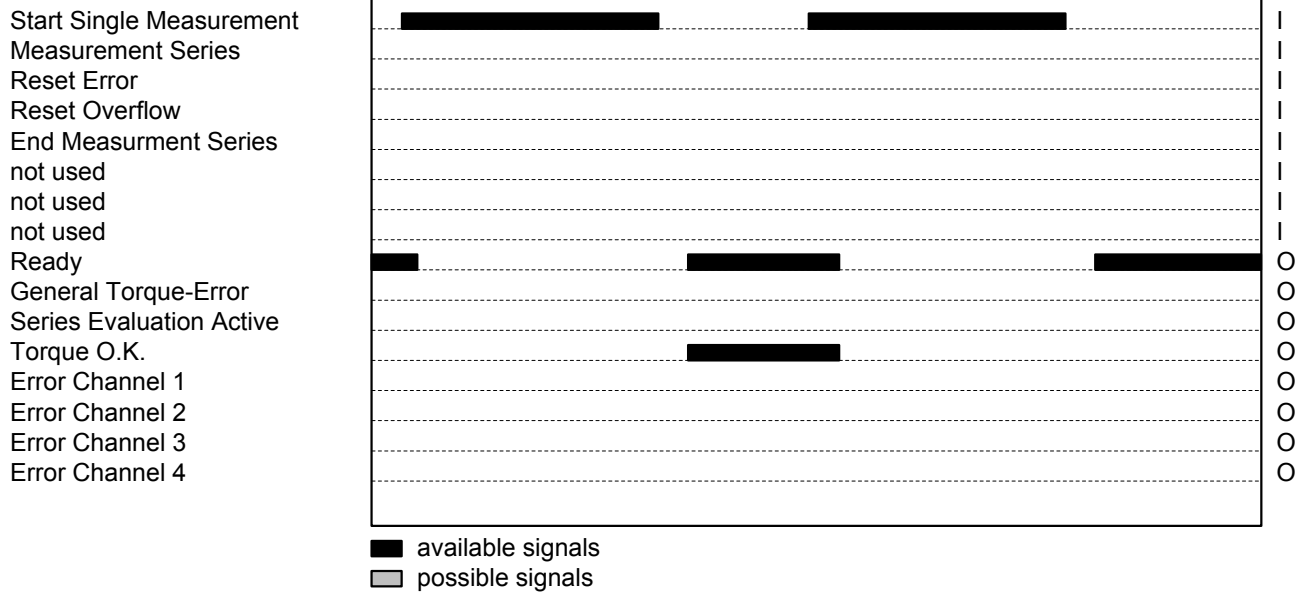

8.2 Measurement Series

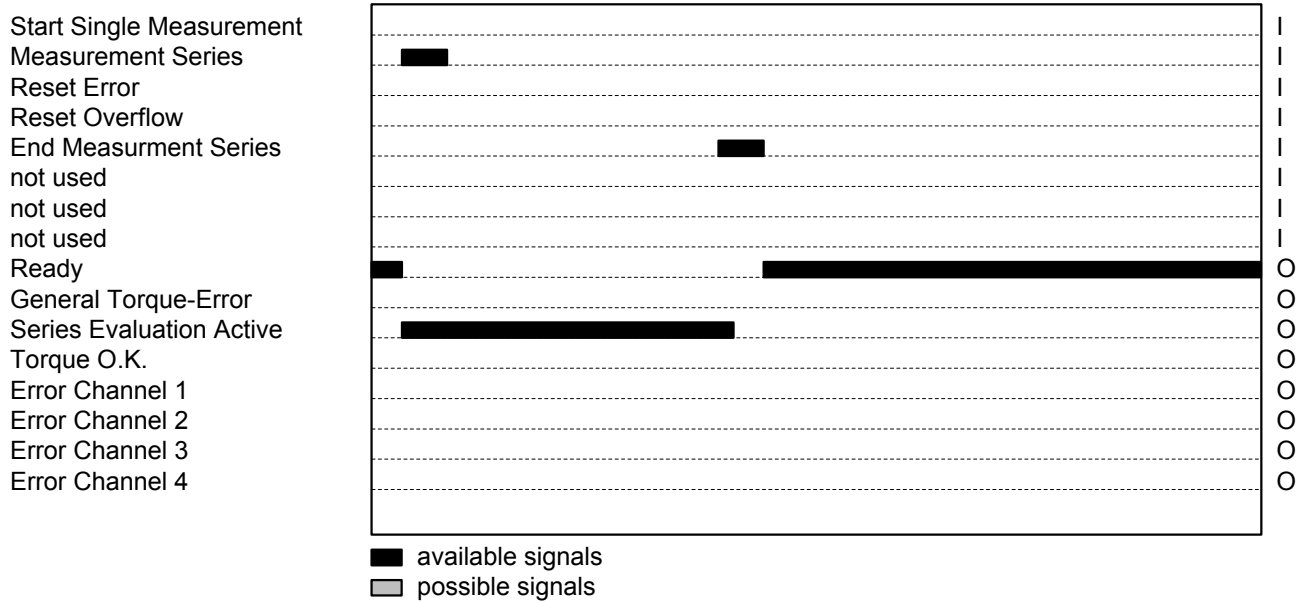

8.3 Reset Errors

Start Single Measurement
 Measurement Series
 Reset Error
 Reset Overflow
 End Measurement Series
 not used
 not used
 not used
 Ready
 General Torque-Error
 Series Evaluation Active
 Torque O.K.
 Error Channel 1
 Error Channel 2
 Error Channel 3
 Error Channel 4

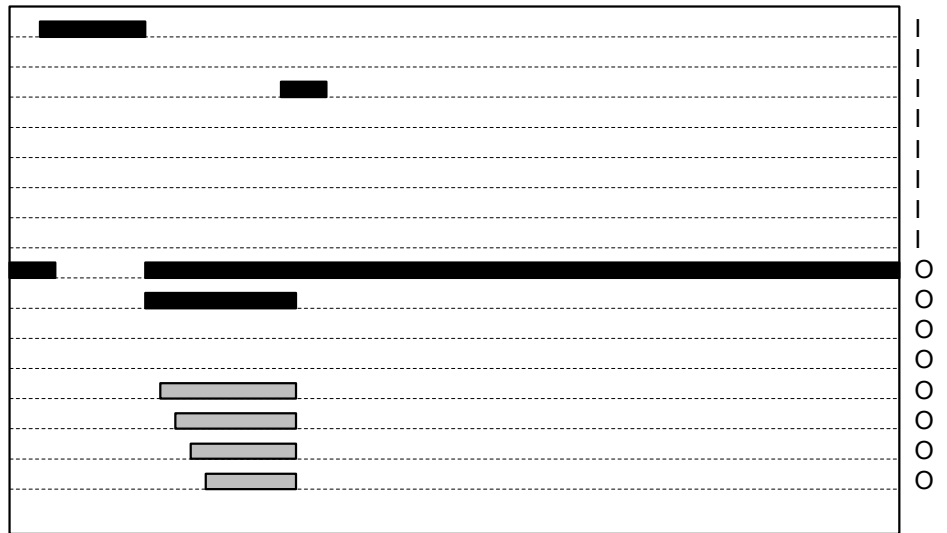

9. UPGRADING TO NEW SOFTWARE VERSION

- Turn-Off Measuring Instrument
- Remove Front Plate (8 screws)
- Remove E-Card (third card from left)
- Remove programming EPROM (PRG) carefully from its holder

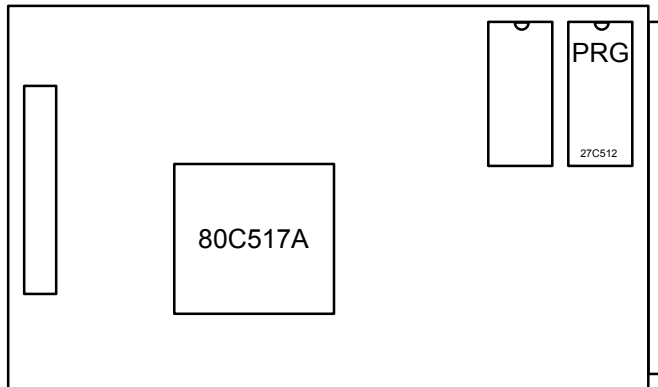

- Insert E-Card
- Turn-On Measuring Instrument
- Wait 10 Seconds
- Remove E-Card (third card from left)
- Insert new EPROM (PRG) - (observe notch placement)
- Replace E-Card
- Mount Front Plate (8 screws)
- Turn-On Measuring Instrument
- Display will show:

BATTERY EMPTY;
RECHECK
PARAMETERS

- Push key "SELECT"
- Input all values as described in paragraph 4

10. TECHNICAL DATA/SPECIFICATIONS

Manufacturer DEPRAG SCHULZ GMBH u. CO.
Address Kurfürstenring 12 - 18 Postfach 1352
D-92224 Amberg D-92203 Amberg
Phone 09621/371-0
Fax 09621/371-120

Model# : ME11-1
ME11-2
ME11-3
ME11-4

Dimensions : 342 x 135 x 335 mm (L x H x W)

Weight : 4.85 kg

Voltage : 115 / 230 V - 60 / 50 Hz - adjustable

Power Supply : 44 VA

Inputs : DC-isolated
10 - 40 V
10 mA

Outputs : DC-isolated
10 - 40 V
500 mA

Measuring Range : 1: 100 pC
2: 500 pC
3: 1000 pC
4: 5000 pC
5: 10000 pC
6: 50000 pC

11. TROUBLE SHOOTING

If a malfunction cannot be removed by the following instructions, we recommend to have the instrument returned to DEPRAG for service!



The instrument can only be operated, maintained, and repaired by personnel familiar with the device and instructed with its dangers.

PROBLEM	REASON	SOLUTION
Display is not on and Messages or Measuring Results are not shown	Instrument is not on	Turn on instrument with toggle switch on back
	Fuses blown	Replace Fuse in power connection
Display is on; Messages or Measuring Results are not shown	Connection Cable between Display and CPU is interrupted	Remove Front Plate and check Cable
Display is not on; Messages or Measuring Results are shown	Background lighting is not o.k.	Re- check Connection Cables (2 cables from the keypad card to the display)
Keypad does not function	Connection Cable between Display and CPU is interrupted	Remove Front Plate and check Cable
LED's on Front Plate do not function	Connection Cable between Display and CPU is interrupted	Remove Front Plate and check Cable
Ready Signal does not change from "0" to "1"	Power Supply not o.k.	Re-check wiring from X1 or X2 (see paragraph 3.1.1 or 3.1.2)
	Unit is in Test-Mode	Change Operating Mode to "Automatic" (paragraph 4)

PROBLEM	REASON	SOLUTION
Measuring Instrument does not react upon receipt of start signal	Instrument is not on -----	Turn on instrument with toggle switch on back -----
	Unit is in Menu Mode -----	Exit Menu Mode by use of PREV-Key -----
	Power Supply not o.k. -----	Recheck wiring from X1 or X2 (see paragraph 3.1.1 or 3.1.2) -----
	Unit is in Test-Mode	Change Operating Mode (paragraph 4)
Measuring Results too low	Calibration Values are not o.k.	Input correct Calibration Values (paragraph 4)
	Start-Signal timed incorrectly	Recheck Start Signal (paragraph 1)
	Installation Sequence incorrect	Recheck Installation Sequence (paragraph 1)
Measuring Results too high	Calibration Values are not o.k.	Input correct Calibration Values (paragraph 4)
	Installation Sequence incorrect	Recheck Installation Sequence (paragraph 1)
Standard Deviation too high	Start-Signal incorrectly timed	Recheck Start Signal (paragraph 1)
	Installation Sequence incorrect	Recheck Installation Sequence (paragraph 1)
Measuring Results are changing	Start-Signal timed incorrectly -----	Recheck Start Signal (paragraph 1) -----
	Installation Sequence incorrect -----	Recheck Installation Sequence (paragraph 1) -----
	Connection Cable defective	Recheck or replace connection cable

12. EC-CONFIRMITY DECLARATION

EC-Conformity Declaration according to the EC-Machine-Guidelines 98/37/EC, Amendment IIA

We,

DEPRAG SCHULZ GMBH & CO.
PO Box 1352
D-92203 Amberg

hereby confirm, that the design of the

ME11-1
ME11-2
ME11-3
ME11-4

conforms to the following, relevant regulation:

- EC-Machine-Guidelines, Version 98/37/EC, Amendment No. 1 and No. 2.2.

Applicable Standard:

- EN 292

Amberg, 16.03. 2004

Dipl. Ing. (FH) A. Langig
Mr. Design Dept.

13. Service Locations and Authorized Partners

ARGENTINA

ERIN s.a.

Av. Constituyentes 5751
RA-1431 Buenos Aires
Tel./Fax: +54 (0) 11 / 4573.1313

AUSTRIA

Amersin Olschinsky GmbH

Carlberggasse 45
A-1230 Wien
Tel.: +43 (0)1 / 8 69 87 66
Fax: +43 (0)1 / 8 65 16 97
Internet: <http://www.amersin.at>
e-mail: information@amersin.at

AUSTRALIA

De Rossi Industrial Pty. Ltd.

Unit 1 – 2 / 600 Liverpool Road
Strathfield South, N.S.W. 2136
Tel.: +61 (0)2 / 8732.7200
Fax: +61 (0)2 / 8732.7299
e-mail: sales@derossi.com.au

BELGIUM

Aijkens en Zumpolle B.V.

Postbus 29
NL-5306 ZG
Brakel/Niederlande
Tel.: +31 (0)4 18 / 67 18 16
Fax: +31 (0)4 18 / 67 32 17
Internet: <http://www.zumpolle.net>
e-mail: info@zumpolle.net

BRAZIL

METALFEMA Ltda.

Rua Saõ Pedro, 786
Saõ Leopoldo – RS –
BRAZIL
ZIP 93.010-260
Tel.: +55 (0) 51 / 592.4050
Fax: +55 (0) 51 / 590.1856
e-mail: mtfma@zaz.com.br

PR CHINA

DEPRAG China

DEPRAG Assembly Technologies Co., Ltd.
No. 5, Xinghan St, Bld. A#06-16
Suzhou 215021, P.R. China
Tel.: +86 (0) 512 – 6767 – 1108
Fax: +86 (0) 512 – 6767 – 1109
Internet: www.deprag.com.cn
e-mail: biz@deprag.com.cn
e-mail: d.hua@deprag.com.cn

CROATIA

SM AUTOMATIKA D.O.O

Trg i. Kukuljevica 6
HR-10090 Zagreb
Tel.: +385(0)13 89 41 79
Fax: +385(0)13 87 89 78
Internet: <http://www.sm-automatika.hr>
e-mail: info@sm-automatika.hr

CZECHIA/SLOWAKIA

DEPRAG CZ a.s.

ul. T.G. Masaryka 113
CZ -50781 Lázně Bělohrad
Tel.: +420 (0) 4 93 / 79 24 11
Fax: +420 (0) 4 93 / 79 25 12
Internet: <http://www.deprag.com>
e-mail: info@deprag.cz

DENMARK

DEPRAG Scandinavia AB

Gap Sundins väg 3
SE-63346 Eskilstuna
Tel.: +45 (0) 98 57 22 50
Fax: +45 (0) 98 57 22 53
Internet: <http://www.deprag.com>
e-mail: keld.branner@get2net.dk

ESTLAND

Pneumacon OY

Läkkisepäntie 4
FI-00620 Helsinki
Tel.: +358 (0) 9 / 7288.160
Fax: +358 (0) 9 / 7288.1610
Internet: <http://www.pneumacon.fi>
e-mail: info@pneumacon.fi
e-mail: harry.lindroos@pneumacon.fi

FINLAND

Pneumacon OY

Läkkisepäntie 4
FI-00620 Helsinki
Tel.: +358 (0) 9 / 7288.160
Fax: +358 (0) 9 / 7288.1610
Internet: <http://www.pneumacon.fi>
e-mail: info@pneumacon.fi
e-mail: harry.lindroos@pneumacon.fi

FRANCE

DEPRAG France

9, rue du Général Frère
F-67500 Haguenau
Tel.: +33 388 / 06.14.17
Fax: +33 388 / 93.01.08
e-mail: depragfrance@evc.net

GERMANY

Werk Amberg

Kurfürstenring 12-18,
D-92224 Amberg
Postfach 1352,
D-92203 Amberg
Tel.: +49 (0) 9621 / 3 71-3 71
Fax: +49 (0) 9621 / 3 71-1 20
Internet: <http://www.deprag.com>
e-mail: info@deprag.de

GREAT BRITAIN

DEPRAG Limited

Holly Farm Business Park
Honiley, Kenilworth
Warwickshire CV8 1NP
Tel.: +44 (0) 1926 485480
Fax: +44 (0) 1926 485481
Internet: www.deprag.co.uk
e-mail: m.searle@deprag.co.uk

GREECE

D. Panayotidis – J. Tsatsis s.a.

6 Pireos Street – Moschaton-
Athen
Tel.: +30 (0) 1 / 4810.817-8-9
Fax: +30 (0) 1 / 482 96 73

HUNGARY

ADLER '91

Export/Import Kereskedelmi
Takarék u. 18/B
H-8800 Nagykanizsa
Tel./Fax: +36 (0) 93 / 314 633
e-mail: adler91adlovits@broadband.hu

Nóniusz Tool Trading House Ltd.

Köbányai út. 47/6
H-1101 Budapest
Tel.: +36 (0) 1 / 260 030 30
Fax: +36 (0) 1 / 260 060 83
Internet: <http://www.noniusz.hu>
e-mail: noniusz@noniusz.hu

IRAN

NACCARSON AIR TOOLS Co., Ltd.

Azadi Ave. No. 625
IR-Tehran 14 588
Tel.: +98 (0) 21 / 6006602 + 6015656
Fax: +98 (0) 21 / 6009451

IRELAND

Production Equipment Ltd.

Riverside Commercial Estate
IRL-Galway
Tel.: +353 (0) 91 / 745 100
Fax: +353 (0) 91 / 751 299
e-mail: sales@productionequipment.ie

ITALY

DREX PALLOTTI S.r.l

Via A. Manzoni, 19
I-20090 Vimodrone/Mi
Tel.: +390 02 / 2740 0561 + 0569
Fax: +390 02 / 2740 0607
e-mail: pallotti@drex.com

JAPAN

NIPPON GESCO Ltd.

P.O. Box 255 Kyobashi Tokyo
Ginza Matsuyoshi Bldg.
17 – 8, 7-Chome, Ginza,
Chuo-Ku, Tokyo
Tel.: +81 (0) 3 / 3542.2400
Fax: +81 (0) 3 / 3542.2420
e-mail: mail@gesco.co.jp

KOREA (South)

Handtools

DONG WON POWER-TECH.INC.

108-10 Moonjung-Dong

Songpa-Ku

Seoul, Korea

Tel.: +82 (0) 2 / 409.1344

Fax: +82 (0) 2 / 409.1345

e-mail: kilpyungdw@dreamwiz.com

Screwdriving / Assembly Technology

Fatec Co.Ltd.

#903, Sunglim B/D 257

Chulsan-Dong

Kwangmyung-City,

Kyunggi-Do

Tel.: +82 (0) 2 / 2 688.2152

Fax: +82 (0) 2 / 2 688.2842

e-mail: fatec@chollian.net

e-mail: fatec@fatec.co.kr

LITHUANIA

HIDROTEKA

P.O. Box 572

LT-3028 KAUNAS

Tel.: +370 (0) 37 / 352195

Fax: +370 (0) 37 / 351952

e-mail: hidroteka@hidroteka.lt

LUXEMBOURG

Comptoir Technique et Industriel

321, Route d'Arlon

L-8011 Strassen

Penang, MALAYSIA

Tel. +352 / 31 31 40

Fax: +352 / 31 31 95

MALAYSIA

FI INNOVATION ENTERPRISE

175, MK D Jalan Bahru

Balik Pulau 11000

Penang, MALAYSIA

Tel. +60/13/ 449.0386 / +60/16/ 403.6797

Fax: +60/4/ 866.0785

e-mail: farisfi@tm.net.my

NETHERLANDS

Zumpolle B.V.

Postbus 29

NL-5306 ZG

Brakel/Niederlande

Tel.: +31 (0) 4 18 / 67 18 16

Fax: +31 (0) 4 18 / 67 32 17

Internet: <http://www.zumpolle.net>

e-mail: info@zumpolle.net

NORWAY

Deprag Scandinavia AB

Gap Sundins väg 3

SE-63346 Eskilstuna

Universal Import

Tel.: +47 (0) 2 / 2681.530

Fax: +47 (0) 2 / 2199.127

POLAND

ELKREM SPOLKA Z O.O.

ul. Wielki Row 40B

87-100 Torun

Tel. +48 / 56 / 662.3881

FAX +48 / 56 / 662.3882

e-mail: elkrem@to.onet.pl

PORTUGAL

Anibal Pires Lda.

A.P. 23

E.N. 1 – Mourisca do Vouga

P-3750 TROFA AGD

Tel.: +351 (0) 234 / 646.820

Fax: +351 (0) 234 / 646.815

Internet: <http://www.anibalpires.pt>

e-mail: anibalpires@mail.telepac.pt

SINGAPORE

Testel Systems Pte Ltd

1200 Depot Road # 04-07/09

Singapore 109675

Tel.: +65 / 6271-3688

Fax: +65 / 6271-8866

Internet: <http://www.testel.com.sg>

e-mail: sunny@testel.com.sg

SLOVENIA

MB-NAKLO D.O.O.

Toma Zupana 16

SLO-4202 NAKLO

Tel.: +386 (0) 4 / 277 17 00

Fax: +386 (0) 4 / 277 17 17

e-mail: mb-naklo@siol.net

SPAIN

ALCOTAN SISTEMAS S.A.

p° de la Direccion, nmro. 95,
local

E-28039 Madrid

Tel.: +349 (0) 1 / 311.17.84 + 311.18.01

Fax: +349 (0) 1 / 311.60.53

e-mail: alcotansis@jazzfree.com

Barcelona office:

Passeig de la Mare de Déu del

Coll, 122-124

E-08023 Barcelona

Tel.: +349 (0) 3 / 2 19 77 43

SWEDEN

DEPRAG Scandinavia AB

Gap Sundins Väg 3

S-633 46 Eskilstuna

Tel.: +46 (0) 16-12 61 10

Fax: +46 (0) 16-13 31 88

Internet: <http://www.deprag.se>

e-mail: info@deprag.se

SWITZERLAND

Limatec Automation AG

Schlachthausstrasse 15

CH-2540 Grenchen

Tel.: +41 (0) 32 / 6542904

Fax: +41 (0) 32 / 6542901

Internet: <http://www.limatec.ch>

e-mail: office@limatec.ch

TAIWAN

I HEN MACHINE Co.Ltd.

6F-9, No. 12, Lane 609, Sec. 5

Chung-Hsin Road,

San-Chung City

241 Taipei Hsen

Tel.: +886 (0) 2 / 2999.6766

Fax: +886 (0) 2 / 2999.6236

TURKEY

MEKA AUTOMOTIVE ASSEMBLY EQUIPMENTS

Dicle Caddesi, Tunca Sokak No : 6

Beysukent - Beytepe - Ankara -

TURKEY

Tel. +90 / 312 / 236 2558

Tel. +90 / 312 / 236 2559

FAX +90 / 312 / 236 0991

e-mail: melih@me-ka-assembly.com

www.me-ka-assembly.com

USA, MEXICO, CANADA

DEPRAG INC.

645 Hembry St. / P.O. Box 1554

Lewisville, TX 75057-4726

Phone: +1 / 972 / 221 – 8731

Fax: +1 / 972 / 221 – 8163

Toll Free: (800) 4 DEPRAG

Internet: <http://www.deprag.com>

e-mail: deprag@depragusa.com

VENEZUELA

Suministros Tecnicos SUMTEC C.A.

Av. Francisco de Miranda, Centro Plaza

Torre C, Piso 16, Oficina C16 A-B

Urb. Los Palos Grandes

Caracas 1060

Tel.: +58 (0) 212 – 28 56 41 0

Fax.: +58 (0) 212 – 28 51 94 7

DEPRAG

DEPRAG SCHULZ GMBH u. CO.

Postfach 1352, D-92203 Amberg
Kurfürstenring 12-18, D-92224 Amberg

☎ (09621) 371-0

Fax (09621) 371-120

Internet: <http://www.deprag.com>

e-mail: info@deprag.de



ZERTIFIZIERT NACH DIN EN ISO 9001

Mrz-04 Änderungen vorbehalten / Technical alterations reserved